

Luis Chícharo  
Iwona Wagner  
Maria Chicharo  
Małgorzata Łapińska  
Maciej Zalewski

# PRACTICAL EXPERIMENTS GUIDE FOR ECOHYDROLOGY



University of Algarve  
Faculty of Marine  
and Environmental Sciences  
Campus de Gambelas  
8005-129 - Faro, Portugal  
[www.ualg.pt](http://www.ualg.pt)



Centro de Ciências  
do Mar do Algarve  
University of Algarve  
Campus de Gambelas  
8005-129 - Faro, Portugal  
[www.ccmarmar.ualg.pt](http://www.ccmarmar.ualg.pt)



University of Algarve  
Campus de Gambelas  
8005-129 - Faro, Portugal  
[www.icce.com.pt](http://www.icce.com.pt)



International Institute  
Polish Academy of Sciences  
European Regional Centre  
for Ecohydrology  
*under the auspices of UNESCO*  
3, Tylna Street, 90-364 Lodz, Poland  
[www.erce.unesco.lodz.pl](http://www.erce.unesco.lodz.pl)



University of Lodz  
Department of Applied Ecology  
12/16, Banacha Street, 90-237 Lodz, Poland  
[www.biol.uni.lodz.pl/~kes](http://www.biol.uni.lodz.pl/~kes)



UNESCO Regional Bureau for Science and Culture in Europe  
(BRESCE)  
Palazzo Zorzi, Castello 4930 30122, Venice, Italy  
[veniceoffice@unesco.org](mailto:veniceoffice@unesco.org)  
<http://portal.unesco.org>



UNESCO International Hydrological Programme  
Division of Water Sciences  
1, rue Miollis 75732, Paris Cedex 15, France  
<http://www.unesco.org/water/ihp/>

#### UNESCO's Copyright

##### Copyright 2009 UNESCO

This publication may be reproduced in whole or in part and in any form for educational or non-profit purposes without special permission from the copyright holder, provided acknowledgement of the source is made. UNESCO would appreciate receiving a copy of any publication that uses this publication as a source. No use of this publication may be made for resale or for any other commercial purpose whatsoever without prior permission in writing from UNESCO.

##### First edition 2009

The designations employed and the presentation of the material in this publication do not imply the expression of any opinion whatsoever on the part of the United Nations concerning the legal status of any country, territory, city or area or of its authorities, or concerning delimitation of its frontiers or boundaries. Moreover, the views expressed do not necessarily represent the decision or the stated policy of the UNESCO, nor does citing of trade names or commercial processes constitute endorsement.

Cover Design and photos: Małgorzata Łapińska

ISBN: 978-989-20-1702-0

Typesetting: Universidade do Algarve, Faro



**List of contributions:****Chapter 1. PHOSPHORUS: AQUATIC ECOSYSTEMS' EXTERNAL SUPPLY AND BALANCE AGAINST HYDROLOGICAL PATTERNS OF TRIBUTARIES.**

*Iwona Wagner*- University of Lodz (Poland)  
*iwwag@biol.uni.lodz.pl*

**Chapter 2. DENITRIFICATION AS AN INTEGRATIVE ELEMENT OF RESERVOIRS RESTORATION.**

*Agnieszka Bednarek*- University of Lodz (Poland)  
*agnik@biol.uni.lodz.pl*

**Chapter 3. THE USAGE OF THE N/P RATIO AS A PREDICTION TOOL FOR EUTROPHICATION AND NUTRIENT LIMITATIONS.**

*Julian Oxmann*- University of Bremen (Germany)  
*JOxmann@web.de*

**Chapter 4. EFFECTS OF NUTRIENT AND LIGHT ENRICHMENT ON PHYTOPLANKTON GROWTH.**

*Ana Barbosa and Rita Domingues*-University of Algarve (Portugal)  
*abarbosa@ualg.pt, rbdomingues@ualg.pt*

**Chapter 5. CAN ENZYMES SUPPLY CYANOBACTERIAL BLOOMS?**

*Adrianna Trojanowska* –University of Wroclaw (Poland)  
*adrianna.trojanowska@ing.uni.wroc.pl*

**Chapter 6. WHICH ARE THE PARAMETERS THAT CAN CONTROL BLOOMS EVENTS IN THE LAGOONS?**

*Manos Koutrakis, Georgios Syslaos and Eleni Tryfon* - Fisheries Research Institute, University of Thrace (Greece)  
*manosk@inale.gr*

**Chapter 7. GRAZING IMPACT OF MICROZOOPLANKTON UPON PHYTOPLANKTON PRODUCTION.**

*Ana Barbosa and Rita Domingues* - University of Algarve (Portugal)  
*abarbosa@ualg.pt, rbdomingues@ualg.pt*

**Chapter 8. ANALYSIS OF DYNAMICS AND SUCCESSION OF FILTERING ZOOPLANKTON IN DIFFERENT HYDROLOGICAL CONDITIONS.**

*Adrianna Wojtal-Frankiewicz* - University of Lodz (Poland)  
*adwoj@biol.uni.lodz.pl*

**Chapter 9. MAY THE PRESENCE OF BIVALVES AFFECT THE DEPOSITON OF SPM AND ASSOCIATED POLLUTANTS, i.e. SPILLED HYDROCARBONS?**

*Juan Carlos Colombo*-University of La Plata (Argentina)  
*colombo@museo.fcnym.unlp.edu.ar*

**Chapter 10. MAY BIVALVES BE USED TO CONTROL TOXIC ALGAE BLOOMS?**

*Luis Chicharo*- University of Algarve (Portugal)  
*lchichar@ualg.pt*

**Chapter 11. HOW DO DIFFERENT GROWTH FORMS OF AQUATIC PLANTS INFLUENCE THE OXYGEN CONCENTRATION WITHIN A WATER BODY?**

*Georg Janauer*- University of Vienna (Austria)  
*georg.janauer@univie.ac.at*

**Chapter 12. USE OF RIPARIAN PLANTS TO REMOVE CADMIUM FROM ESTUARINE SEDIMENT.**

*Manuela Moreira da Silva*- University of Algarve (Portugal)  
*msanti@ualg.pt*

**Chapter 13. MODELLING ESTUARINE ECOLOGICAL RESPONSE TO DIVERSE HYDROLOGICAL PATTERNS. BOTTOM-UP CONTROL.**

*Radhouan Ben-Hamadou*- CCMAR, University of Algarve (Portugal)  
*bhamadou@ualg.pt*

**Chapter 14. REGULATION OF BIOTIC FEEDBACKS BY HYDROLOGY. TOP-DOWN EFFECTS.**

*Maciej Zalewski*- ERCE, University of Lodz (Poland)  
*mzal@biol.uni.lodz.pl*

*erce@erce.unesco.lodz.pl*

**Chapter 15. ANALYSIS OF JUVENILE FISH BEHAVIOUR IN DIFFERENT HYDROLOGICAL CONDITIONS.**

*Piotr Frankiewicz*- University of Lodz (Poland)  
*franek@biol.uni.lodz.pl*

**Chapter 16. FISH COMMUNITY AS A TOOL IN ENVIRONMENTAL QUALITY ASSESSMENT.**

*Małgorzata Łapińska*- University of Lodz (Poland)  
*malapi@biol.uni.lodz.pl*

**Chapter 17. ARE MALES SPECIMENS MORE ADEQUATE TO DETECT ANTROPOGENIC IMPACTS?**

*María Alexandra Chicharo*- University of Algarve (Portugal)  
*mchichar@ualg.pt*

**Chapter 18. HOW DO WETLAND VEGETATION CHARACTERISTICS DEPEND ON HYDROLOGY, TOPOGRAPHY AND SUBSTRATE BIOGEOCHEMISTRY?**

*Ruben Lara*- University of Bremen (Germany)  
*ruben.lara@zmt-bremen.de*

**Chapter 19. MAY WATERSHED LAND COVER BE USED AS AN INDICATOR OF POTENTIAL ANTHROPOGENIC IMPACT ON WATER RESOURCES?**

*Ramiro Sarandón and Verónica Guerrero*- University of la Plata (Argentina)  
*sarandon@netverk.com.ar*

**Chapter 20. AN EXPERIENCE ON ECOLOGICAL ASSESSMENT OF ESTUARINE OR SEA WATERS.**

*Lorenzo Marquez, Carlos Jiménez, Jesus Morales*- Instituto Andaluz de Investigación y Formación Agraria, Pesquera, Alimentaria y de la Producción Ecológica (IFAPA)  
*jmorales@cica.es*

**Chapter 21. CYTOGENETICS OF BIVALVES AS POSSIBLE INDICATOR OF ENVIRONMENTAL ADVERSITY**

*Alexandra Leitão*- Instituto das Pescas da Investigação e do Mar (IPIMAR)  
*aleitao@ipimar.pt*

**Acknowledgements**

The editors would like to express their deep appreciation to all the above experts for their contributed to the production of this guide, to UNESCO-BRESCE and to Dr. Philippe Pypaert for their support.

## PREFACE

*Aquatic ecosystems are under increasing pressure due to human activities and changing natural phenomena. Addressing water quality and quantity issues is a crucial matter for human existence and biodiversity conservation. Water ecosystems are used as sources and sinks by a large number of similar activities occurring worldwide. Thus, similar water problems and degradation can be related to similar causes, having similar consequences in different world aquatic ecosystems.*

*Ecohydrology provides the tools to deal with aquatic ecosystems degradation. Ecohydrology is based on a holistic approach to aquatic ecosystems that integrates hydrology and biology for finding the most adequate solutions for the benefit of society and ecosystems. Ecohydrology is a recent science and its application worldwide is growing particularly since “Ecohydrology for Sustainability” was established as one of the five pillars of the 7th Phase of the International Hydrologic Program of UNESCO.*

*Aiming to contribute to the dissemination of the Ecohydrology concept in different types of aquatic ecosystems, this book proposes a series of practical experiments, mostly requiring non-sophisticated laboratory equipment and conditions. The experiments proposed will provide to the water science students a practical knowledge of the methods to identify, analyse and design solutions to water and biodiversity degradation. The student will be guided to analyse and discuss the results of the experiment and draw her/his own conclusions. For further discussion, questions or suggestions readers may use the book webpage [www.icce.com.pt/ehstudents.guide](http://www.icce.com.pt/ehstudents.guide)*

*We are most grateful to the many colleagues that, from around the world, contributed with their knowledge and experience to make this book possible.*

*Special acknowledgment is due to Dr. Philippe Pypaert, from UNESCO-BRESCE, who enthusiastically supported the development and dissemination of the Ecohydrology concept since its beginning.*

*By doing this book we hope to contribute to the creation of a broad vision of the processes occurring at the river basin including coastal regions, mastering the linkage between systems and comprising all the aspects of the water cycle that will allow students and water professionals to develop the integrated ecohydrology based solutions to restore, sustain and improve water quality and biodiversity in OUR aquatic ecosystems.*

*The Editors*

## INTRODUCTION

Aquatic ecosystems are under increasing pressure worldwide. Increasing urbanization, intensive agriculture practices and industrialization are some of the factors contributing to water quality degradation and biodiversity loss.

Cumulatively, climate changes are affecting hydrologic cycles and will pose in the near future more problems to water quantity and quality, in different world regions.

Aquatic ecosystems are very dynamic and are changing fast. Alien species are spreading very fast and threatening biodiversity. Rivers, estuaries and coastal areas are affected by reservoirs and dams. Consistent trend of human migration toward coastal regions increase stress and degradation on estuaries and coastal areas.

All the existing facts and the forecast scenarios call for integrated solutions for water quality and quantity sustainability. Solutions must be based on a deep knowledge of ecosystem processes and functioning. Ecohydrology is a scientific concept applied to environmental problem-solving. It quantifies and explains the relationships between hydrological processes and biotic dynamics at a catchment scale. The concept, developed by the UNESCO International Hydrologic Programme (IHP) and the Man and Biosphere Programme (MAB), is based upon the assumption that sustainable development of water resources is dependent on the ability to restore and maintain evolutionary established processes of water and nutrient circulation and energy flows at the basin scale. Using ecosystem properties as a management tool enhances carrying capacity of ecosystems against human impact. This approach is supported by a profound knowledge of ecosystems functioning, as a basis for twinning the interplay between hydrologic and ecological factors, in order to increase ecosystems robustness and resilience to anthropogenic impacts.

The notion that water quality and biodiversity can be controlled by managing hydrologic parameters, as residence times or freshwater discharge volumes, or biological parameters, as the presence of riparian vegetation or filter feeders, and that integration with existing infrastructures can be made in a synergetic way, are novel approaches to water sciences.

The Ecohydrology approach considers three principles that are expressed in sequential components:

1. **Hydrological:** The quantification of the hydrological cycle of a basin, should be a template for functional integration of hydrological and biological processes.
2. **Ecological:** The integrated processes at river basin scale can be steered in such a way as to enhance the basin's carrying capacity and its ecosystem services.
3. **Ecological engineering:** The regulation of hydrological and ecological processes, based on an integrative system approach, is thus a new tool for Integrated Water Basin Management and Integrated Coastal Management.

This book provides suggestions of practical experiments for addressing different water problems and demonstrates that long-lasting Ecohydrology solutions - based on a deep understanding of the contribution of hydrological and ecological variables to a healthy ecosystems functioning - can be implemented successfully with low costs interventions, in different aquatic ecosystems.

## BOOK STRUCTURE

The chapters of this book present 21 experiments dealing with the major and more frequent causes of degradation of aquatic ecosystems, as eutrophication, toxic algal blooms, chemical contamination, removal of native vegetation and biodiversity loss, occurring at the entire river basin, from upstream riverine systems until downstream estuarine and coastal ecosystems.

Each experiment is assigned to one of the three Ecohydrology principles: eg, to Principle I - chapter on the "Effects of nutrient and light enrichment on phytoplankton growth"; to Principle II – "May bivalves be used to control toxic algae blooms?" and to Principle III – "Regulation of biotic feedbacks by hydrology: top-down effects".

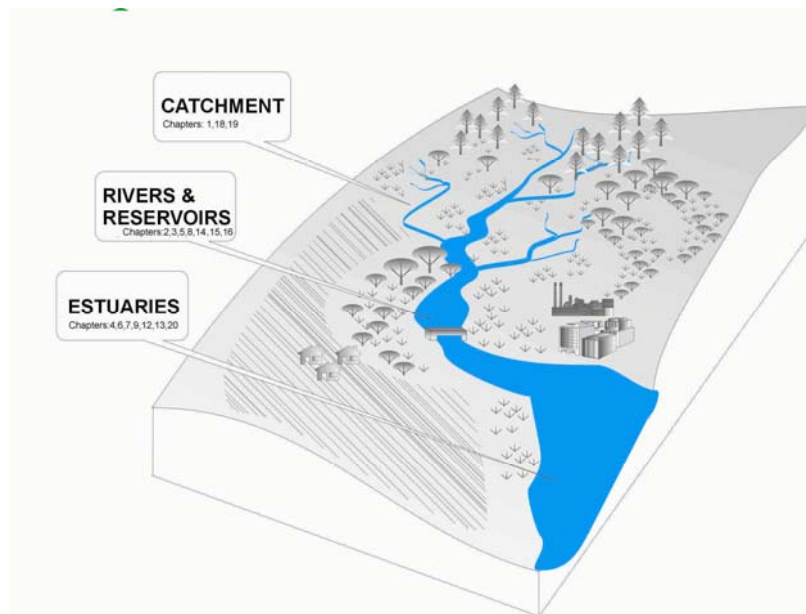

**Figure 1-** *Chapters distribution according to different aquatic ecosystems: catchment, reservoirs, rivers and estuaries.*

Each chapter is organized in an introduction – explaining how the proposed experiment may contribute, in practical terms, for solving the degradation of aquatic ecosystems, in the light of the EH approach; a general description of the experiment – indicating the materials and equipments needed to develop the experiment, in the field (sampling material), laboratory and data analysis required; an experimental design section – providing a detailed description of the experiment and indicating and explaining all steps needed for the development of the experiment; a data organization section –guiding in the organization of the data in formats to be used in statistical analysis and graphical design; a data analysis section – guiding the students in the analysis of the clues to find the most relevant outcomes from the experiment; and a discussion section – formulating the questions for students to reply based on the analysis of the results and in the light of the Ecohydrology approach.

## TABLE OF CONTENTS

Acknowledgments		1
Preface		2
Introduction		3
Book Structure		4
Table of contents		5
<b>Chapter 1.</b>	<b>PHOSPHORUS: AQUATIC ECOSYSTEMS' EXTERNAL SUPPLY AND BALANCE AGAINST HYDROLOGICAL PATTERNS OF TRIBUTARIES</b>	7-16
<b>Chapter 2.</b>	<b>DENITRIFICATION AS AN INTEGRATIVE ELEMENT OF RESERVOIRS RESTORATION</b>	17-22
<b>Chapter 3.</b>	<b>THE USAGE OF THE N/P RATIO AS A PREDICTION TOOL FOR EUTROPHICATION AND NUTRIENT LIMITATIONS</b>	23-26
<b>Chapter 4.</b>	<b>EFFECTS OF NUTRIENT AND LIGHT ENRICHMENT ON PHYTOPLANKTON GROWTH</b>	27-30
<b>Chapter 5.</b>	<b>CAN ENZYMES SUPPLY CYANOBACTERIAL BLOOMS?</b>	31-36
<b>Chapter 6.</b>	<b>WHICH ARE THE PARAMETERS THAT CAN CONTROL BLOOMS EVENTS IN THE LAGOONS?</b>	37-40
<b>Chapter 7.</b>	<b>GRAZING IMPACT OF MICROZOOPLANKTON UPON PHYTOPLANKTON PRODUCTION</b>	41-46
<b>Chapter 8.</b>	<b>ANALYSIS OF DYNAMICS AND SUCCESSION OF FILTERING ZOOPLANKTON IN DIFFERENT HYDROLOGICAL CONDITIONS</b>	47-50
<b>Chapter 9.</b>	<b>MAY THE PRESENCE OF BIVALVES AFFECT THE DEPOSITON OF SPM AND ASSOCIATED POLLUTANTS, i.e. SPILLED HYDROCARBONS?</b>	51-54
<b>Chapter 10.</b>	<b>MAY BIVALVES BE USED TO CONTROL TOXIC ALGAE BLOOMS?</b>	55-58
<b>Chapter 11.</b>	<b>HOW DO DIFFERENT GROWTH FORMS OF AQUATIC PLANTS INFLUENCE THE OXYGEN CONCENTRATION WITHIN A WATER BODY?</b>	59-62
<b>Chapter 12.</b>	<b>USE OF SALTMARSH PLANTS TO REMOVE CADMIUM FROM ESTUARINE SEDIMENT</b>	63-64
<b>Chapter 13.</b>	<b>MODELLING ESTUARINE ECOLOGICAL RESPONSE TO DIVERSE HYDROLOGICAL PATTERNS. <i>BOTTOM-UP CONTROL</i></b>	65-68
<b>Chapter 14.</b>	<b>REGULATION OF BIOTIC FEEDBACKS BY HYDROLOGY. <i>TOP-DOWN EFFECTS</i></b>	69-74
<b>Chapter 15.</b>	<b>ANALYSIS OF JUVENILE FISH BEHAVIOUR IN DIFFERENT HYDROLOGICAL CONDITIONS</b>	75-78
<b>Chapter 16.</b>	<b>FISH COMMUNITY AS A TOOL IN ENVIRONMENTAL QUALITY ASSESSMENT</b>	79-90
<b>Chapter 17.</b>	<b>ARE MALES SPECIMENS MORE ADEQUATE TO DETECT ANTROPOGENIC IMPACTS?</b>	91-96
<b>Chapter 18.</b>	<b>HOW DO WETLAND VEGETATION CHARACTERISTICS DEPEND ON HYDROLOGY, TOPOGRAPHY AND SUBSTRATE BIOGEOCHEMISTRY?</b>	97-100
<b>Chapter 19.</b>	<b>MAY WATERSHED LAND COVER BE USED AS AN INDICATOR OF POTENTIAL ANTHROPOGENIC IMPACT ON WATER RESOURCES?</b>	101-108
<b>Chapter 20.</b>	<b>AN EXPERIENCE ON ECOLOGICAL ASSESSMENT OF ESTUARINE OR SEA WATERS</b>	109-114
<b>Chapter 21.</b>	<b>CYTOGENETICS OF BIVALVES AS POSSIBLE INDICATOR OF ENVIRONMENTAL ADVERSITY</b>	115-118
<b>APPENDIX</b>		119
<b>Glossary of terms</b>		119-120
<b>Internet resources</b>		121



## 1. PHOSPHORUS: AQUATIC ECOSYSTEMS' EXTERNAL SUPPLY AND BALANCE AGAINST HYDROLOGICAL PATTERNS OF TRIBUTARIES.

### Chapter Objectives

- To present factors determining dynamics of phosphorus concentrations in rivers and their effect on other aquatic ecosystems supply;
- To calculate phosphorus and sediments loads supplying aquatic ecosystems;
- To calculate aquatic ecosystems phosphorus and sediments balance.



*Pilica River, Poland (photo M. Wysocki)*

### EH principle: 1 – quantification of processes and threats

#### INTRODUCTION

##### Water run-off and nutrients export

Precipitation waters falling down over the area of a watershed is transferred by the gravitation to the lowest reaches of the catchment – to a river system. The amount of the transported water (runoff) depends mostly on climate (i.e., precipitation, temperature, evapotranspiration), catchment geology (e.g., soil permeability, rate of infiltration to aquifers) and land cover (e.g., vegetation, permeability changes due to human interventions). Urbanisation and degradation of the natural vegetation cover and are among the major reasons for the excessive runoff, which alters hydrological characteristics of aquatic ecosystems. River basins covered with high vegetation biomass possess almost 100% higher potential for water retention than grasslands (Llorens et al., 1997). Increase of the area of impermeable surfaces due to urbanisation enlarges the surface runoff and therefore rivers discharge, even 6-7 times.

Besides of water, the run-off transports solutes and sediments - products of both the natural and man induced soil weathering. Yet again, this is the landcover degradation, due to such activities as unsustainable agriculture, grazing or deforestation, that highly contribute to this process. Low plant biomass and enhanced erosion open the nutrients cycles in the landscape, and cause their excessive export to waters. It increases even more due to fertilizing or stocking (**Figure 1**).

The status and functioning of a catchment is therefore reflected by the quantity and quality of

run-off, and thus the quality and quantity (hydrological pattern) of its aquatic ecosystems. Nutrients downstream transport

The solutes and sediments reaching rivers with runoff, are transported further downstream to other aquatic ecosystems – rivers, reservoirs, wetlands, lakes and estuaries (the receivers). Therefore finally, this is the hydrological pattern of a supplying river (tributary) that directly regulates the timing and extend of the amount of nutrients reaching these ecosystems in a given time (load). By doing this, it determines not only the quality of water, but also ecological processes taking place in these ecosystems. The timing and amount of nutrients supply may determine productivity of the ecosystems and e.g., probability of appearance of the eutrophication symptoms (Wagner, 2002). This is why quantification of hydrological and ecological processes in a catchment scale – according to the 1st ecohydrology principle – is an important prerequisite for diagnosing the threats and opportunities for the aquatic ecosystems, and elaboration a strategy for its management.

##### Phosphorus and aquatic ecosystems vulnerability

Phosphorus is an important product of natural processes and, recently, anthropogenic activities in a catchment. After being transported to aquatic ecosystems it enriches the waters and thus increases their trophic status (eutrophication), causing a number of consequences. These includes excessively increased productivity, accelerated succession

and terrestriation of lakes, biodiversity loss, oxygen depletions, fish dying or appearance of toxic cyanobacteria during hot weathers, among others (cit).  
 Not all the aquatic ecosystems, are the same resistant to increased phosphorus loading. Natural and semi-natural rivers and wetlands,

with variable habitats, higher biodiversity and stable functioning of the ecosystem are usually more resistant to pollution. They possess a higher absorbing capacity against the increased phosphorus loading, due to higher rate of self-purification (particularly in tropical and sub-tropical regions and during summers in

### DIFFERENCES IN NUTRIENT CYCLING

- a) Natural catchment - closed nutrient cycling, minimal loss to freshwater
- b) Agricultural catchment - closed nutrient cycling, high supply and loss to freshwater

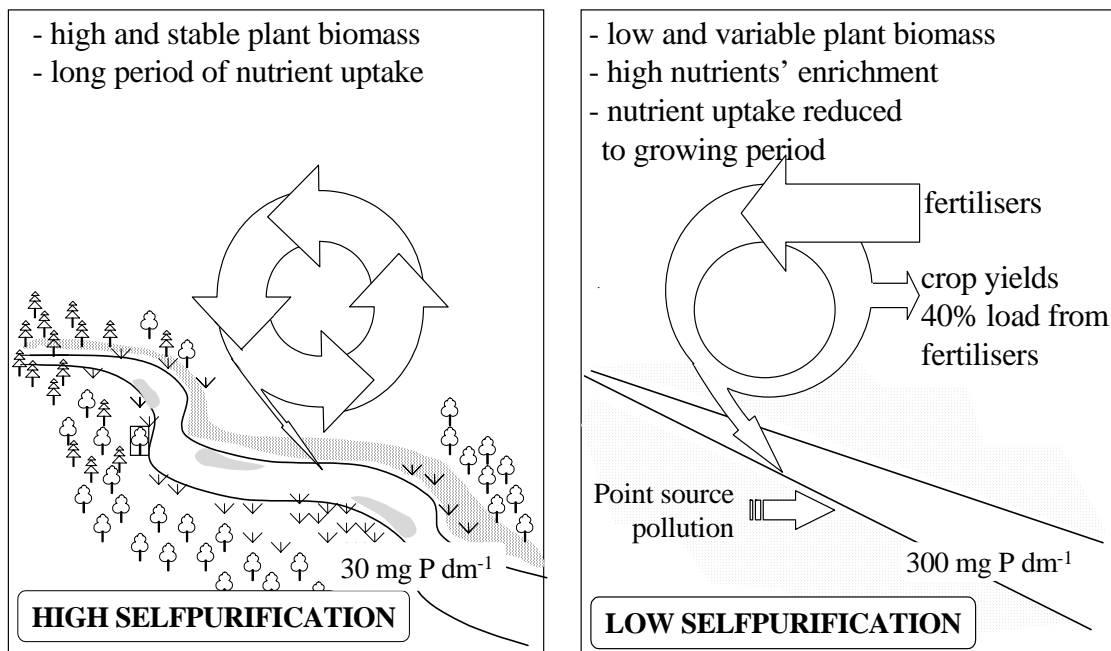

**Figure. 1.** Effect of Catchment degradation on biogeochemical cycles in a catchment (Zalewski et al., 2001).

temperate climate). In such rivers, nutrients and other pollutants can be assimilated in the biomass of riparian vegetation, protecting them against the phosphorus supply from runoff. Riverbed vegetation closes the nutrients cycles and protects from downstream transport. Such ecosystems are to a greater extent able to maintain unchanged ecosystem structure and functions, even in spite of increasing nutrients concentrations. Channelised rivers do not possess this ability. Decomposition processes prevail over production, degrading water quality and contributing to phosphorus loss to downstream water bodies.  
 Lakes and, particularly, reservoirs are among the most vulnerable ecosystems. Decreased flow

and water exchange enhances the retention of both the suspended solids (by sedimentation) and solutes (by assimilation, physical adsorption, chemical bounding in sediments), degrading water quality. The accumulated nutrients are easily transferred into the biological cycles. Higher temperatures and more stable water masses increase the ecosystems productivity. At the same time, high depths and low transparency, together with variable water levels in reservoirs restricts establishment of vascular vegetation on the banks. This gives competitive advantage of algae and cyanobacteria and results with their intensive growth (cit). In the consequence, the use of lakes and reservoir for water supply, recreation and fisheries may be

restricted, causing the consequences described at the beginning of this section.

#### Definitions:

- **concentration** – the amount of a substance dissolved in a given amount of water [e.g.,  $\mu\text{g dm}^{-3}$  or  $\text{mg dm}^{-3}$ ]
- **discharge** (rate of flow) – the amount of water flowing through a river channel cross-section in a given time [e.g.,  $\text{m}^3 \text{s}^{-1}$ ,  $\text{dm}^3 \text{s}^{-1}$ ]
- **load** – the amount of a substance or sediments transported by a river cross-section in a given time [e.g.,  $\text{tons day}^{-1}$  or  $\text{kg h}^{-1}$  or  $\text{kg day}^{-1}$ ]. Load is calculated by multiplying the concentrations of a substance in the river's water by the river's discharge.
- **balance** – a difference between the total amount of water/nutrients/sediments inflowing to a given ecosystem and total amount of water/nutrients/sediments out-flowing from a given ecosystem.

## ELABORATING THE EXPERIMENT

### 1. General description

The exercise will be performed on rivers – inflowing to and outflowing from of a selected aquatic ecosystem – lake, reservoir or wetland. It may be also design for an estuary or subcatchment (measurement on the inflow only). The goal of the exercise will be to determine the concentrations of phosphorus and sediments in the investigated rivers. A long term experiment design and sampling at different weathers will additionally allow to determine the dynamics of the concentrations against the rivers hydrological pattern. Selecting rivers with different catchment development (e.g., different percentage of agricultural use or agricultural and urban catchment) will show the effect of its degradation on water quality and indicate threats – major sources of pollution.

Calculation of the long-term results will allow to determine phosphorus and sediments loads and balance for a selected aquatic ecosystem.

Single experiment (short-time design) will allow for calculation of phosphorus and sediments concentrations and loads supplying the selected aquatic ecosystem in a particular day of the experiment.

The experiment will involve the measurements of:

- phosphate phosphorus ( $\text{PO}_4\text{-P}$ ) and Total Phosphorus (TP) concentrations;

- Total Suspended Solids (TSS), Total Organic Solids (TOSs), Total Mineral Solids (TMSs) concentrations;
- discharge (Q).

### 2. Experimental design

#### Selection of sampling sites

Depending on a type of the ecosystem selected for the phosphorus and nutrient balance calculations, the appropriate stations will be chosen for sampling. They will be distributed at each river inflowing to and outflowing from the investigated ecosystem. To perform a complete nutrients balance, the sampling should also include others, artificial inflows and outflows, e.g., drainage systems, sewage outflows, water intakes. **Figure 2** shows an example location of sampling stations at a reservoir, lake, wetland and estuary/subcatchment.

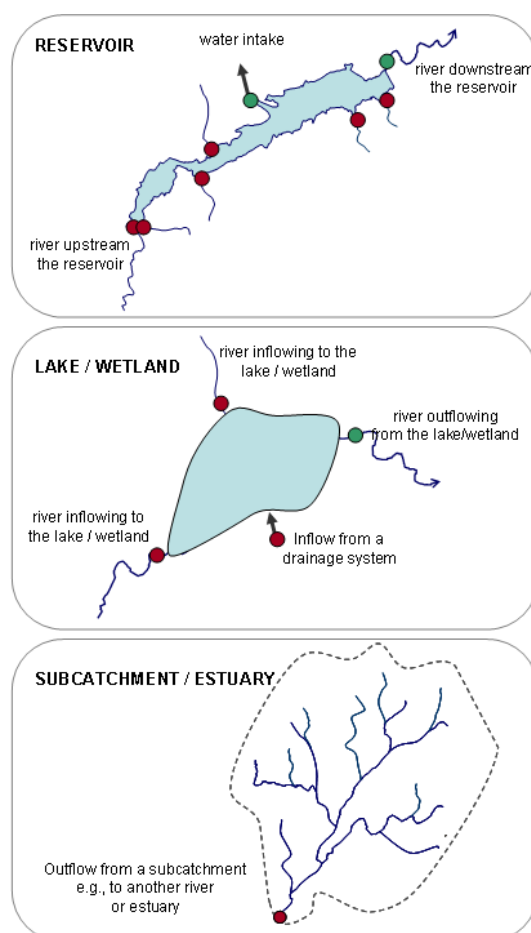

**Figure 2.** Location of sampling stations for the reservoir, lake and subcatchment water, nutrients and sediments balance.

Depending on the size of the ecosystem and available information, the sampling stations can be identified based on maps, aerial photographs, satellite images, by driving or even flying over the area. The last method is particularly useful in the case of large systems, which are supplied with tributaries dynamically changing in number (e.g., low river reaches during dry and wet seasons in hot climates) or switching their course (e.g., after El Niño/La Niña events), if the recent maps are not available (**Photo 1**).



**Photo 1.** Identification of the outflows from the Enwaso Ngiro swamp, upstream the Lake Natron, Kenya, flying over the area (photo: I. Wagner).

In order to obtain reliable phosphorus balance of a water body, the sampling stations at its tributaries should be located as close to the investigated ecosystem, as possible. It is always a great advantage if the sampling stations are located at a bridge. This facilitates taking a representative sample of water from a main current of the river. You can also use own measurements to establish hydrological monitoring network based on own flow velocity measurements, if such a network does not yet exist in the area. Finally, following a road to a bridge in low-inhabited areas and difficult access to a river helps the identification of the sampling station during the following field excursions. You may also use GPS for identification of sampling stations during next measurements.

#### Timing of sampling

Reliable nutrient balance and recognition of the relationships between concentrations, loading and hydrology, requires a long-term design of the experiment. A number of measurements should be performed in different seasons (dry

and wet or winter, spring, summer, autumn) and various weather and hydrological situations, i.e. at stable low discharge, rising and falling water level/hydrograph at flood events, during floods of different intensity and amplitude. During floods, the measurements should be taken more often e.g., every day. In case of small catchments and rivers (average discharge below  $10 \text{ m}^3 \text{ s}^{-1}$ ), the frequency should increase to every few hours, or even few times per hour (river with average discharge below  $2 \text{ m}^3 \text{ s}^{-1}$ ).

Taking a single measurement following the presented methodology, will not give a reliable result on a nutrients balance and will not allow the analysis of the nutrients dynamics against hydrological pattern and its seasonal changes. It may be however considered as a pilot study, or a general methodology exercise.

### 3. Materials and equipment

The task consists of three parts – a) field measurements, b) laboratory analyses and c) data processing.

#### a) Field measurements

You will need to take with you equipment for water sampling, physical parameters measurements, and flow velocity measurements. These include:

#### Collecting of water samples

- water sampler, to collect water for chemical analysis. If the samples will be taken from a bridge, it may be constructed from a basket with a fixed long rope. If the water is collected from a bank, a smaller container can be fixed to a stick, that will reach to the main current of a river from a bank. In case of a large river, the sampling may be performed from a boat;
- suspended sediment sampler, to collect water for suspended solids analysis you may use a special sampler for suspended sediments (**Figure 3**). If the sampler is not available, you can use for the analysis the water collected with a water sampler;
- polyethylene bottles for water storage. For each sampling site, you will need one small (about 250 ml) and one bigger bottle ( $0,5\text{-}5 \text{ dm}^3$ ), cleaned and rinsed with distilled water.
- water proof marker or labels for bottles.
- filtering set – filtering syringe or vacuum filter and the expendable filters (pore diameter -  $45 \text{ }\mu\text{m}$ );

- container – for transporting the water samples in darkness and, preferably, temperature about + 4 °C.

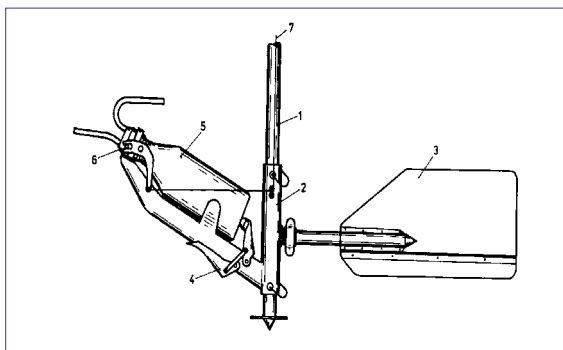

**Figure 3.** *Water Sampler for suspended solids analysis.*

#### Measuring physical parameters of water

- thermometer or temperature meter;
- conductivity meter;
- dissolved oxygen content meter;
- pH meter or litmus paper.

#### Measuring flow velocity

- current meter. There is a number of current meters available: anemometer and propeller velocity meters, electromagnetic velocity meters, Doppler velocity meters and optical strobe velocity meters. They differ with the accuracy of the measurement, but anyone will be proper for this exercise;
- measuring tape (preferably length equal to the width of the investigated rivers channels).

#### Others

- clothing: water proof boots to walk on the river banks or into the river for samples collecting, water proof jacket, safety jacket.

#### b) Laboratory analyses

This part of the exercise will take place in a chemical laboratory. If no chemical laboratory available, you can use a desk in a well ventilated room, with access to water.

Phosphorus concentrations analysis

Depending on availability you may use one of the following equipment:

- spectrophotometer and appropriate reagents for phosphate phosphorus (PO<sub>4</sub>-P) concentration analysis. Classical chemical methods use basic reagents available in chemical stores (e.g., Golterman). Recently, there is also a number of easy-to use chemical kits produced by chemical

companies, which added in a guided order facilitate the method, shorten the time and increase the accuracy of the results;

or

- chromatograph – can be used for the analyses of PO<sub>4</sub>-P and concentrations of other ions dissolved in the water sample (**Photo 2**).

**Determination of the TP concentrations** will require mineralization of the sample. For this purpose you may need one of the following equipment/method:

- microwave and respective reagent sets, according to the method provided by the company ;
- chemical methods (cit); update.



**Photo 2.** *Chromatograph for analyzing ions in water samples (European Regional Centre for Ecohydrology under the auspices of UNESCO, Lodz, Poland; photo: K. Izydorczyk).*

#### Suspended solids concentration analysis

To perform the suspended solids analyses you will need one of the following two sets:

- filtering set – the same as for water;
- laboratory scale with the accuracy of 0,0001 mg;
- desiccator (150 deg. C)
- muffle furnace (550 deg. C) – for TOSs and TMOs analysis;
- blender and spectrophotometer (for TSSs determination, only).

#### c) Data analysis

One of the following two sets will be needed in order to compute the final results:

- computer with a basic software for data calculation, statistical analysis and graphic representation of the results;
- calculator.

**Safety information**

*Considering that the sampling should take place in different weather conditions, including wet weather, you need to make sure that you use appropriate clothing.*

*If the samples are taken from a bridge, be aware of the traffic safety rules.*

*Always use rubber boots when entering water. Always use safety jacket when you walk into deep water or board a boat.*

*Use rubber gloves when working in waters of unknown quality and disinfect your hands after sampling.*

*Beware of touching electric devices with your hands wet, and use electric equipment carefully.*

**4. Experiment description****a) Field experiments****Water sampling**

The first activity at the site is water sampling. It should be done before other measurements, in order to avoid disturbing of the river bottom, influencing the quality of the water sample. In wide rivers and multi-channel rivers sampling should be performed at a few locations within the channel cross-section, representing different conditions (e.g., current and banks, different channels, etc).

You will use two bottles for each sample storage: the bigger one (0,5-5 dm<sup>3</sup>) will store unfiltered water, which will then be used for TSS and TP analysis (use the water or sediment sampler). The volume of the collected water depends on a method used for TSS calculation. If you chose the spectrophotometer method, you will need only 250 ml of water. If you use the filter method, the amount of the collected water depends on the amount of the suspended solids (water transparency), that you need to estimate in the field. The less suspended solids the more water is needed to obtain reliable results.

The second bottle (about 250 ml) will store water for chemical analysis. It should be filtered immediately after the sampling, using the filtering set.

**Measuring physical parameters of water**

Physical parameters – water temperature, pH, conductivity and dissolved oxygen should be measured in the same sampling stations where the water is taken for the chemical analysis. Temperature, pH and conductivity may be measured in the bottle, directly after the sampling, in the unfiltered water. Dissolved

oxygen should be measured directly in the river, as water aeration may increase during sampling.

**Measuring flow velocity**

The flow velocity is needed for calculation of rivers discharge and will be then necessary for the calculation of the water and nutrient budget. The flow velocity can be measured in the following ways:

- **Hydrological monitoring data:** In the river systems where a gauging system is operating, you may contact respective authorities responsible for daily measurements and data handling. You will need the water level or discharge data for each day of the performed sampling.
- **Current meter:** If no hydrological monitoring network is operating in the area, you can use a current meter to measure the river instantaneous flow, which can be later on recalculated to a river discharge. There are several publications providing detailed methodology for the flow velocity measurements and discharge calculations (cit) which will not be described in detail here. Basically, the flow velocity is measured at specific sections/points, evenly distributed within a cross-section of a river channel (**Figure 3**). You stretch a measuring tape across the channel to define these sections/points (**Photo 3**). Then measure a depth and flow velocity at each section. Their number as well as the depths at which the measurements should be done in each section, depends on a river depth, width and the shape of the channel cross-section. The general rules are (Dingman, 1994. Grant & Dawson, 1997):
  - ✓ the stream should be divided into a minimum of equal 15 subsections;
  - ✓ subsections should be wider than 3/10 of a foot;
  - ✓ subsections must be less than 10% of the total stream channel cross-section;
  - ✓ the number of subsections must be limited to those that can be measured in a reasonable amount of time.
- **Direct measurement:** If no current meter is available – you can use an orange or a colour ball, easily visible in the water, or a wooden stick collected in the sampling area. You throw the ball into the main river current and measure the time it takes to flow along a

distance of 10 meters. The distance is measured with the measuring tape, along the river bank.

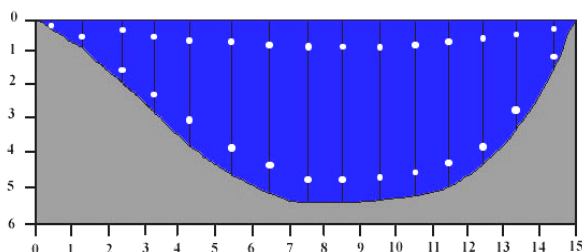

**Figure 3.** An example of a stream cross section and location of measurements sections/points for flow velocity measurements.



**Photo 3.** Measuring a river flow velocity. Enwaso Ngiro, Kenya (photo I. Wagner)

## b) Laboratory experiments

### Phosphorus concentrations analysis

The methodology of the phosphorus measurement depends on the availability of the equipment and the chosen method (see the section: 3 – Material and equipment).

The following phosphorus fractions will be measured, using the same methodology:

- $\text{PO}_4\text{-P}$  – phosphate phosphorus (reactive soluble phosphorus). The analysis is performed using the water filtered in the field.
- TP – total phosphorus. The analysis is performed using the raw (unfiltered) water sample. The sample has to be mineralized before the chemical analysis.
- Mineralization of the sample can be performed using the microwave digestion method or a chemical method (cit).

### Suspended solids concentration analysis

The suspended solids concentrations can be measured using one of the following methods:

**Filtration:** the known volume of raw (unfiltered) water will be filtered through a 45  $\mu\text{m}$  filter of a known weight (0,001 accuracy). The water should be well shaken before filtering. You need to make sure, that once a known amount of water is placed in the filtering device, it is filtered entirely, and no sediments is left on the filtering pot's ringers. The filter is then placed in a desiccator and dried for 24 h in a temperature of 150 deg. C (determination of the TSSs). The filter will be weighted again after this time. After weighting, the filter will be placed in 550 deg. C, burned there for 24 h and weighted again after (determination of the TOSs and TMSs).

**Spectrophotometric method** (only TSSs determination):– 250 ml of raw (unfiltered) water is placed in a blender and homogenised for 2 minutes. The light absorbance is measured on a spectrophotometers at wave length of XXXX, against the blank sample – check (citation).

## 5. Organizing the data

### Organizing the data

The field data and laboratory readings will be organised in the protocols provided in the appendix.

### Phosphorus concentrations calculations

The same rules applies for both  $\text{PO}_4\text{-P}$  and TP concentration.

- if you use chromatograph or spectrophotometer method with a ready chemicals kits, you will receive a reading of phosphorus concentration in  $\text{mg dm}^{-3}$  or  $\text{ug dm}^{-3}$ , as a result. No further calculations are needed;
- if you use a traditional chemical spectrophotometer method, your will receive a percentage of the light absorbed by the sample after the  $\text{PO}_4\text{-P}$  reaction with the reagents, as a result. This result have to be then re-calculated using a calibration curve , prepared for the specific reagents used in the reaction (cit);
- total suspended solids concentration calculations.

### Filtration:

The Total Suspended Solids (MTSM) concentration is calculated as a difference between the weight of the filter ( $M_0$ ) used for the

filtering of the known amount of water (V) and its weight after 24 hour drying in 105°C (M1):

$$\text{MTSM} = (M1 - M0)/V \text{ [mg dm}^{-3}\text{]}$$

The *Mineral Suspended Solids (MMSM)* concentration is calculated as a difference between the weight of the filter (M0) used for the filtering of the known amount of water (V) and its weight after 24 hour drying in 550°C (M2):

$$\text{MMSM} = (M2 - M0)/V \text{ [mg dm}^{-3}\text{]}$$

The *Organic Suspended Solids (MOSM)* concentration is calculated as a difference between the weight of the Total Suspended Solids (MTSM) and the Mineral Suspended Solids (MMSM):

$$\text{MOSM} = \text{MTSM} - \text{MMSM} \text{ [mg dm}^{-3}\text{]}$$

#### **Spectrophotometric method:**

The reading gives the results of TSSs concentration in mg dm<sup>-3</sup>, and there is no need for their further recalculating.

Instantaneous discharge calculations

- hydrological monitoring: data are given as an instantaneous discharge or water level. If you want to re-calculate water level to discharge or the opposite, you need to use a site-specific compensation curve. The compensation curve can be received from the authorities collecting and handling the monitoring.
- current meter: Flow velocity measured at each section (Fig. 3) is multiplied by its area (A), which gives a discharge (Q) through this particular cross-section as a result:
- $Q_1, 2, 3, \dots, n = F_1, 2, 3, \dots, n * A \text{ [m}^3 \text{ s}^{-1}\text{]}$  update
- the area (A) of each section can be calculated by multiplying its depth by the section width.
- the total discharge (QT) for the river channel cross-section is calculated as the sum of the partial discharges through all the sections:
- $QT = \sum Q_1, 2, 3, \dots, n$
- direct measurement: update.

#### **Phosphorus and sediments loads and balance calculations**

In order to receive (daily, monthly, yearly) load of any substance transported by a river or artificial inflow, you multiply the substance concentration in particular sampling site by the instantaneous discharge in a river cross-section at this site and by the relevant time. Make sure, that the units in all the elements of the equation are relevant to each other, e.g.:

$$\text{Lday} = C * Q * 86400$$

Where:

Lday – load [kg]

C – concentration [kg m<sup>-3</sup>]

Q – instantaneous discharge [m<sup>3</sup> s<sup>-1</sup>]

86400 – the number of seconds per day

In order to calculate the phosphorus or suspended solids balance for a selected aquatic ecosystem, you will need to calculate loads for each of its tributaries and artificial inflows, and outflows in a given time (day, month, year).

The total water balance will be a difference between the inflow and outflow.

Considering that concentrations in rivers are changing very dynamically between seasons, in a daily period and depending on weather conditions, a single measurement can never be a basis for a calculation of a yearly loads or balance. The loads should be calculated on a basis of at least few measurements a month (Wagner, in press).

#### **b) Basic statistical analysis**

All the physical measurements and chemical analysis should be performed in three repetitions for each sample/measurement, in order to assure accuracy of the measurement. The average of these three results will be used in further statistical analysis.

Estimation of the relationships between the independent variables (discharge) and dependent variables (PO<sub>4</sub>-P, TP, TSSs, TOSs, TMSs) can be done by the Pearson regression or a polynomial function.

A significance of the differences between the nutrient concentrations transported during floods and stable flows, or during rising and falling hydrograph, can be estimated using ANOVA and Tukey's tests.

#### **c) Making graphs**

Prepare the following graphs :

##### **hydrology:**

- river cross-sections' profiles– based on the depth measurements (linear graphs);
- hydrograph (if gauging data are available) – a linear graph showing changes of the instantaneous discharge at the investigated cross-sections;
- mean instantaneous discharge for each cross-section – a bar graph with mean, minimum and maximum values for all the sampling stations.

##### **concentrations:**

- TP, PO<sub>4</sub>-P, TSSs, OSSs and MSSs concentrations changes (bars) against the discharge (a linear graph – 1a);

- TP, PO<sub>4</sub>-P, TSSs, OSSs and MSSs concentrations vs discharge relationship (point graph with approximation of a linear or polynomial function); for: stable low discharge, water level/discharge increase, water level/discharge decrease.

#### loads and balance:

- loads of TP, PO<sub>4</sub>-P, TSSs, OSSs and MSSs for each inflow and outflow from the researched ecosystem (a bar graph, with the inflowing loads indicated in plus and outflowing loads in minus).

### 6. Analysing the results

Based on the analyses of the obtained results, answer the following questions:

1. What are the relationships between the discharge of the investigated rivers and the concentrations of the phosphorus (TP and PO<sub>4</sub>-P)?
2. What are the relationships between the discharge of the investigated rivers and the concentrations of the suspended solids (TSSs, OSSs and MSSs)?
3. Are there any differences in the above relationships on between different tributaries? What is the reason?
4. Are there any differences in the above relationships on the sampling stations located at the inflow to a researched system comparing to those outflowing from the system? What could be the reason for these differences?
5. What are the differences between the nutrient loads supplying the system during the stable flows and floods?
6. What are the differences between the nutrient loading during the rising and falling hydrograph phase?
7. Do your system retain or release nutrients? What is the reason for this? What can be the consequences?
8. Can you think of any ecohydrological solutions to decrease the nutrients loading and improve the balance in this ecosystem?

### 7. Discussion

#### Nutrients concentrations and loads changes against the hydrological patterns

The amount and timing of phosphorus transported by rivers is determined by several factors interacting with each other and changing over a year. The mechanisms of the concentration changes with discharge depends on hydrological cycle pathways, and the role of its particular components in runoff formation from a catchment. This relationship depends also on the nutrient sources prevailing in the catchment. In degraded catchments with a considerable contribution of non-point source pollutants, the concentration of nutrients during high water periods increases. In case of several point-pollution sources, which are independent from weather conditions, the concentration may at certain point decrease with discharge intensification. Both pollutions result in a mixed pattern (Figure 4).

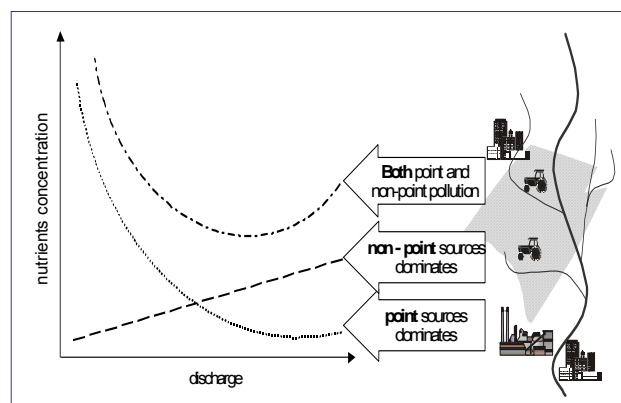

**Figure 4.** General relationships between increase of river discharge resulting from intensive precipitation in a catchment area and nutrient concentration in the river, depending of the pollution sources prevailing in the catchment (Somlyódy et al.; changed).

### The general pattern of nutrients transport by rivers in degraded catchments are:

- the highest nutrient concentrations are observed during first phase of flood, while the water rise (nutrient-condensing stage);
- before the river discharge reaches the maximum, nutrient concentrations start to decrease and continue decreasing during the water discharge decline (nutrient-dilution stage);
- consequently, nutrients' loads transported in the nutrient-condensing stage are higher than in the nutrient-dilution stage;
- during flush floods (short duration and high amplitude) the nutrients loads transported are higher than during floods of low amplitude and long duration time at the same river due to high hydraulic load (amount of the transported water). However, the nutrient concentrations during moderate floods can be higher than during flash floods, when dilution of transported contaminants may occur;
- nutrient concentrations are greater during frequent moderate floods than during those of longer duration and lower variability. Nutrient loads transported in the first case are usually also higher.

### Nutrients balance in reservoirs, lakes and wetlands

The difference between the inflow and outflow of nutrients and matter to an ecosystem determines its nutrients/matter balance. In those reservoirs which are characterised with a low water exchange rate – lakes, reservoirs, wetlands - the annual phosphorus and sediment balance is often positive. It means, that the supplying load exceeds the ecosystem release, and the system basically retains nutrients. This process contributes to water quality degradation due to eutrophication. It results may involve toxic (cancerogenic) cyanobacterial blooms, having social and economic consequences for the local human populations and the ecosystems.

Siltation of reservoirs and terrestrialisation of lakes and wetlands is another issue. Siltation fills up dams and reduces the reservoirs volume, contributing to flooding in rivers, coastal areas and estuaries, which are usually inhabited by large human populations. Siltation leads to a loss of water storage capacity and a shorter lifespan or costly maintenance for expensive infrastructure designed to support hydropower generation, irrigation, or domestic and industrial uses (GEO 4, MEA). Finally, it considerably

reduces the flux of sediment to the world's coasts, severely impacting oceans ecosystems.

The nutrients balance may however differ considerably in between seasons and depend on hydrological conditions. E.g., some of the shallow, medium size man-made reservoirs may release more nutrients during summers. Considerable nutrients pool, located at this time in biotic structure (mostly phytoplankton, zooplankton, fish), may be flushed out from a reservoir if flush flood occurs.

### Ecohydrological solutions

The 3rd ecohydrology principle provides some ecological engineering based solutions, using dual regulation between hydrological and biological processes, that may be used for improving the situation. They may be used for both reducing the inflow, and increasing the outflow from the reservoirs. The examples of such measures basically include:

- restoring and maintenance of vegetation cover in landscape, by its adaptation to the modified hydrological conditions in degraded catchments ;
- enhancement of nutrients uptake in both natural and constructed systems above the reservoirs - floodplains, wetlands, biofilters;
- hydrodynamic regulations at inflows to the reservoirs (pre-reservoirs), enhancing sedimentation;
- releasing reservoir water in a controlled way, so that the accumulated nutrients and sediments can be released to estuaries .

### REFERENCES

More of the scientific background, examples of applications, solutions and explanation can be found in the following publications:

1. Guidelines for the Integrated Management of the Watershed -Phytotechnology and Ecohydrology:  
[www.unep.or.jp/ietc/Publications/Freshwater/FMS5](http://www.unep.or.jp/ietc/Publications/Freshwater/FMS5).
2. Integrated Watershed Management - Ecohydrology & Phytotechnology- Manual:  
[www.unep.or.jp/ietc/publications/freshwater/watershed\\_manual](http://www.unep.or.jp/ietc/publications/freshwater/watershed_manual).

## 2. DENITRIFICATION AS AN INTEGRATIVE ELEMENT OF RESERVOIRS RESTORATION.

### Chapter Objectives

To demonstrate how hydrological conditions (low or high water level) may:

- Modify denitrification process in littoral zone;
- Temporally enhance denitrification rate, lowering N/P ratio and inhibit phytoplankton growth.



Sulejow Reservoir (photo I. Wagner)

**EH principle: 2 – enhancement of ecosystem absorbing capacity**

### INTRODUCTION

The discharges containing nitrogen and phosphorous compounds may accelerate the eutrophication process and stimulate the growth of algae. The **TN:TP** ratio may be a useful parameter for determining the possibly limiting nutrient (Guildford, Hecky 2000). The N growth limitation can occur when the TN:TP ratio is low (<20), whereas P growth limitation can occur when the TN:TP ratio is high (>50). For this reason, the control of both nutrients is becoming increasingly important in water quality management. Although the phosphorus is often the critical nutrient, the reservoir serves mainly as a nitrogen sink, especially in the case of shallow waterbodies (Nielsen *et al.* 1995, Tomaszek *et al.* 1997, Tomaszek, Czerwiec 2000, Nielsen *et al.* 2001). **Water Retention Time (WRT) is a factor that may modify denitrification rates. Increasing WRT enhances sedimentation in littoral zones of a reservoir, and may contribute to intensification of denitrification rates by increasing the OM content in sediments. It induces accumulation of organic matter and stimulates anaerobic condition in sediments resulting in higher denitrification rates in this areas. Enhanced denitrification lowers the N/P ratio and inhibits phytoplankton growth.** This is especially expected during the spring period (due to highest nitrogen load from the catchment), when water temperatures are low and diatoms, which are not able to fix nitrogen from the atmosphere, dominate in phytoplankton communities. Because of this mainly in spring period denitrification process should be

stimulated for maximal removing of external nitrogen load (Bednarek, Zalewski 2007).

### ELABORATING THE EXPERIMENT

#### 1. General description

The method used in our experiments was based on **direct measurements of N<sub>2</sub> production** from in situ chambers. This method is simple and quick, does not require the use of isotopes, avoids inhibitors, and leaves the sediment vertically intact. The results were in good agreement with the in vitro N<sub>2</sub> flux method (Tomaszek *et al.* 1997). However, a disadvantage of this method is the necessity of taking special precautions to avoid contamination with atmospheric nitrogen. Other limitations are its restriction to shallow reservoirs and the necessity to calculate released N<sub>2</sub> flux due to changes in gas solubility. In situ chamber method may be a useful tool in studies of denitrification in an aquatic environment.

#### 2. Experiment design

Water samples from reservoir, for monitoring N/P ratio, should be taken usually every week. The measurement of denitrification rates in the sediments should be conducted in the littoral zone. Sediment denitrification rates should be measured using an in situ chamber method for direct measurements of gaseous reaction products (**Figure 1**) (Tomaszek 1991, Tomaszek, Czerwiec 2000). The chamber penetrated 10 cm into the sediments and enclosed 21,5 dm<sup>3</sup> of overlying water and had a surface area of 0,073 m<sup>2</sup>. At the beginning of the

measurements denitrification rates, air was pulled out of the burette by a syringe through a needle and displaced by water drawn up from the chamber. After the system was closed and filled with water the chamber was left in place for measured time intervals, ranging from several hours to a few days, to allow gases to

accumulate in the burette. The gases produced in the sediments formed bubbles that rose through the sediments and were collected in a burette placed at the top of the incubation chamber.

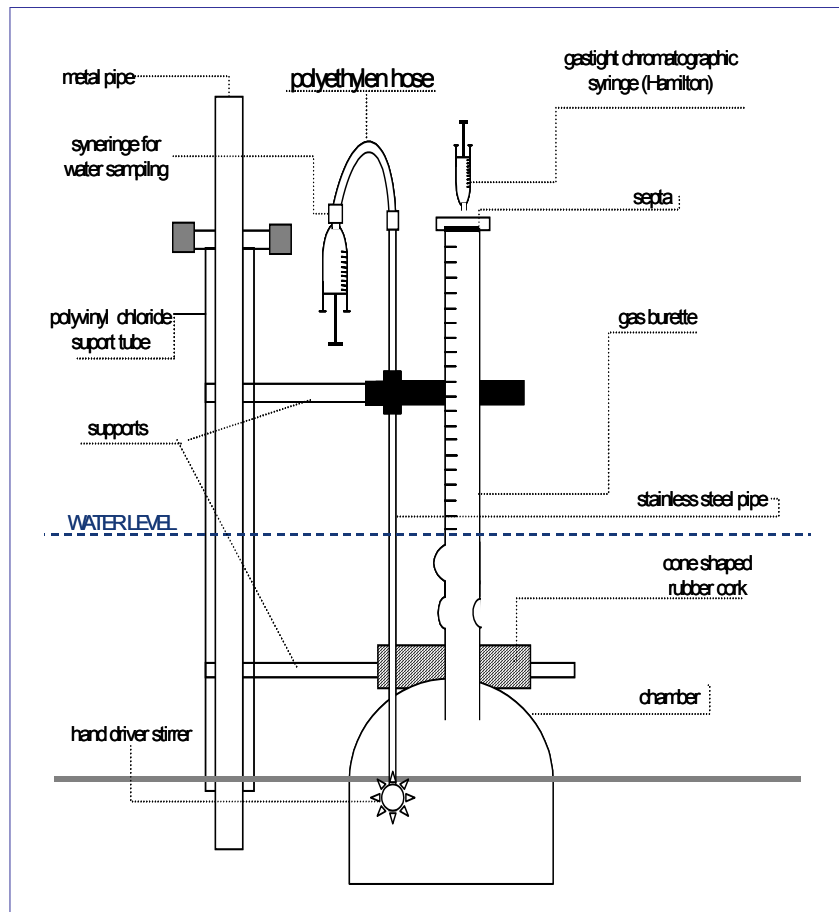

**Figure 1.** Schematic diagram of the chamber for direct measurement of denitrification in sediments (Tomaszek 1991, changed).

The  $N_2$  measured in the head space at the top of the incubation chamber is a combination of the denitrification occurring in the sediments and the amount of  $N_2$  due to equilibration of  $N_2$  dissolved in overlying water ( $N_2$  background). Therefore, the in situ denitrification rate is calculated from the total  $N_2$  flux out of the sediments taking into account the correction for the released  $N_2$  flux due to changes in nitrogen gas solubility (Hodgman *et al.* 1960). The gas samples must be analysed on a Philips gas chromatograph (Tomaszek 1991, Bednarek 2004). The in situ denitrification rate will be calculate from the total  $N_2$  flux out of the sediment. Sediment cores were

collected and organic carbon content was analysed. The results should be calculated as percentage of dry weight.

### 3. Materials and equipment

#### a) Field equipment

You will need to take with you equipment for water sampling and physical parameters measurements. These include:

- water sampler, to collect water for chemical analysis - from a boat;
- polyethylene bottles for water storage. For each sampling site, you will need one small

(about 250 ml) cleaned and rinsed with distilled water;

- water proof marker or labels for bottles;
- filtering set – filtering syringe or vacuum filter and the only one used filters (pore diameter - 45  $\mu\text{m}$ );
- container – for transporting the water samples in darkness and temperature about + 4 °C.

#### b) Laboratory equipment and measurements



#### Water

Water for chemical analysis was filtered directly after sampling through Whatman GF/F filter and analysed for:

- total nitrogen (TN) using Hach test N'Tube (0 do 25 mg/l) (no.10071);
- nitrate nitrogen (N-NO<sub>3</sub>) using Hach test NitraVer 5 or e.g. to [Golterman et al. \(1988\)](#);
- ammonia nitrogen (N-NH<sub>4</sub>) and concentration phosphorus (P-PO<sub>4</sub>) according e.g. to [Golterman et al. \(1988\)](#).

DP and TP concentrations will require mineralization of the sample. For this purpose you may need the following equipment: microwave and e.g. Merck prepared reagents.

For the analyses of other ions concentrations chromatograph can be used.

#### Sediments

- fresh samples of sediment should be dried and subjected to chemical analysis after guiding;
- organic matter (OM) was determined as a mass loss on ignition at 550 °C;
- organic carbon may be determined by the Thiurin method ([Piper 1957](#));
- total nitrogen by the Kjeldahl method.

#### Gases

The gas samples must be analysed on a gas chromatograph ([Tomaszek 1991](#)).

#### c) Data analysis

- data sheet organizer;
- computer with a basic software for data calculation, statistical analysis and graphic representation of the results.

### 4. Data organizing and analysis

#### Organizing the data

Observations of physical and chemical parameters (separately for water and sediments) will be gathered into data sheets (see **Table 1** and **2** in **Annex**). Data with denitrification rate ( $\mu\text{mol N}_2 \text{ m}^{-2} \text{ h}^{-1}$ ) will be gathered into data sheets (see **Table 3** in **Annex**).

#### Basic statistical analysis

The Pearson correlation coefficients (r) between composition of sediments and denitrification rate ( $\mu\text{mol N}_2 \text{ m}^{-2} \text{ h}^{-1}$ ) will be carried out with the Statistica program (data from **Table 4** see **Annex**).

#### Making graphs

Results will be presented in form of figures and tables.

### 5. Analysing the results

Regulation of hydrological processes, by increasing WRT and inundating properly managed littoral zones can contribute to removal of nitrogen via denitrification and decrease eutrophication ([Bednarek, Zalewski 2007](#), [Bednarek et al. 2002](#)).

The following questions should be answered on the basis of achieved data:

1. Which parameters mainly determine denitrification process in littoral zone?
2. What is N/P ratio and water temperature?
3. When is the optimal period for regulation-increasing denitrification process?
4. Where are optimal conditions for regulation-increasing denitrification process?
5. Where is the highest load from the catchment due to human activities?

#### REFERENCES

1. [Bednarek A., Zalewski M. 2007. Potential effects of enhancing denitrification rates in sediments of the Sulejow reservoir.](#)

- Environment Protection Engineering 33(2):35-43.
2. Bednarek A. 2004. Surveys: How to assess and quantify specific issues in watersheds? Lakes & Reservoirs: What happens to nitrogen in a lake? *In*: M. Zalewski M., I. Wagner-Łotkowska (eds.) Integrated Management of the Watershed – Phytotechnology & Ecohydrology – Manual. UNDP/UNESCO.
  3. Bednarek A., Zalewski M., Błaszczuk M., Dąbrowska E., Czerwieniec E., Tomaszek J. 2002. Estimation of denitrification rate in diversified bottom sediments of the Sulejow Reservoir. *In*: Proceedings of the Final Conference of the First Phase of the IHP-V Project 2.3.2.4 on Ecohydrology „ The Application of Ecohydrology to Water Resources Development & Management” Ecohydrology & Hydrobiology 2(1-4):297-304.
  4. Golterman H.L., Clymo R.S., Ohstand M.A.M. 1988. Methods of Physical and Chemical Analysis of Fresh Waters. IBP Hand Book.
  5. Guildford S. J., Hecky R.E. 2000. Total nitrogen, total phosphorus, nutrient limitation in lakes and oceans: is there a common relationship? *Limnology and Oceanography* 45:1213–1223.
  6. Hodgman C.D., Weast R.C., Selby S.M. (eds.) 1960. Handbook of Chemistry and Physics: A Ready-Reference Book of Chemical and Physical Data, 41st ed. Chemical Rubber Publishing Co, Cleveland, OH.
  7. Nielsen K., Nielsen L.P., Rasmussen P., 1995. Estuarine nitrogen retention independently estimated by the denitrification rate and mass balance methods: a study of Norsminde Fjord, Denmark. *Marine Ecology Progress Series* 119:275–283.
  8. Nielsen K., Risgaard-Petersen N., Sømod B., Rysgaard S., Bergø T. 2001. Nitrogen and phosphorus retention estimated independently by flux measurements and dynamic modelling in the estuary, Randers Fjord, Denmark. *Marine Ecology Progress Series* 219:25–40.
  9. Piper C.S. 1957. Soil and Plant Analysis. PWN, Warsaw.
  10. Tomaszek J. 1991. Biochemical transformation of nitrogen compounds in the bottom sediments of the superficial waters. *Rzeszow Technical Univ. J.* 13:1–155.
  11. Tomaszek J. 1995. Problems of preservation and land reclamation of the man-made lake on the Wisłok River in Rzeszow. The Conference of the Polish Academy of Science, November 14–15, 1995, Zabrze, Silesia, Poland. 133–150 pp.
  12. Tomaszek J.A., Gardner W.S., Johengen T.H. 1997. Denitrification in sediments of a Lake Erie Coastal Wetland (Old Woman Creek, Huron, OH, USA). *Journal of Great Lakes Research* 23:403–415.
  13. Tomaszek J. A., Czerwieniec E. 2000. In situ chamber denitrification measurements in reservoir sediments, an example from south-east Poland. *Ecological Engineering* 16:61–71.

## ANNEX

**Table 1.** *Surface water parameters data sheet.*

Surface water parameters	Reservoir:			
	Month, day:	Month, day:	Month, day:	Month, day:
Total nitrogen (mg TN l <sup>-1</sup> )				
Nitrate-nitrogen (mg NO <sub>3</sub> -N l <sup>-1</sup> )				
Nitrite-nitrogen (mg NO <sub>2</sub> -N l <sup>-1</sup> )				
Ammonium – nitrogen (mg NH <sub>4</sub> -N l <sup>-1</sup> )				
Total phosphorus (mg TN l <sup>-1</sup> )				
Nitrate-nitrogen (mg PO <sub>4</sub> -P l <sup>-1</sup> )				
TN:TP				
Water temperature (°C)				
pH				
Dissolved oxygen (mgO <sub>2</sub> l <sup>-1</sup> )				

**Table 2.** *Bottom sediment parameters data sheet.*

Bottom sediment parameters	Reservoir:			
	Month, day:	Month, day:	Month, day:	Month, day:
Organic matter (OM, % of dry weight)				
Organic carbon (OC, % of dry weight)				
Total nitrogen (TN, % of dry weight)				

**Table 3.** *Denitrification rate ( $\mu\text{mol N}_2 \text{ m}^{-2} \text{ h}^{-1}$ ) data sheet.*

Reservoir:				
Denitrification rate ( $\mu\text{mol N}_2 \text{ m}^{-2} \text{ h}^{-1}$ )				
Stations	1 st sampling	2 nd sampling	3 rd sampling	average
1				
2				
3				
4				
5				

**Table 4.** *Ordered data – for statistical analysis.*

Stations	Composition of sediments (% dry mass of sediment)			Temperature ( $^{\circ}\text{C}$ )	Denitrification rate ( $\mu\text{mol N}_2 \text{ m}^{-2} \text{ h}^{-1}$ )
	Organic matter	Organic carbon	Total nitroge n	average	average
1					
2					
3					
4					
5					



### 3. THE USAGE OF THE N/P RATIO AS A PREDICTION TOOL FOR EUTROPHICATION AND NUTRIENT LIMITATIONS.

#### Chapter objectives

To quantify the atomic N:P ratio in an aquarium and add nitrate or phosphate in order to improve the water quality by the reduction of algae growth.



*Cyanobacteria dominated phytoplankton bloom*  
(photo ERCE)

#### EH principle: 1 – quantification of threats

#### INTRODUCTION

Eutrophication appears in aquatic systems by an excess of nutrients (Hutchison 1973). The excess of a nutrient changes the original ratio of nutrient compounds and the growth of algae (e.g. nitrogen-fixing cyanobacteria) may be promoted. Therefore, the **elemental phosphorus/nitrogen ratio is an important parameter, because the P and N control may impede the eutrophication in both lakes and marine environments** (Boesch *et al.* 2006; Lake Winnipeg Stewardship Board 2006). The elemental N:P ratio for co-limitation, which is likely to prevent eutrophication, is about 16. This ratio is derived from the elemental composition of marine phytoplankton. The atomic ratio of N:P:C in marine phytoplankton is ca. 1:16:106 (*Redfield ratio*; Redfield 1934).

An input of nitrogen or phosphorus by human impacts changes the N/P ratio of the water and substrate in environmental settings with an accompanied affect on algae growth. On the other hand, human impacts can also cause nutrient limitations. Especially land reclamations in coastal areas affect the biogeochemical substrate properties by drainage (Dent 1986), which is necessary to reduce the water content and the salinity of the sediment for subsequent crop production. Frequently or permanently flooded sediments are reduced below the surface (> 1 cm depth), because the overlying water reduces the input of oxygen by diffusion and, hence, the electron pressure increases. If iron sulphides are formed by sulphate reduction under reducing conditions, the formation of sulphuric acid by the oxidation of these sulphides drastically lowers sediment pH, when the buffering capacity, through  $\text{CaCO}_3$  for example, is insufficient. Particularly, the phosphorus content in sediment and soils is highly

dependent on substrate pH values (Lindsay 1979). The acidification causes the dissolution of easily available calcium phosphates and the dissolved phosphate leaches and/or relatively insoluble alumina or iron phosphates precipitate. Finally, the acidification causes a phosphorus deficiency and crop or tree growth is restricted. Changes of the geochemical substrate characteristics may affect the sustainability of fisheries.

Correlations between phosphorus and nitrogen contents in leaves and substrate can be used as a preliminary indicator for possible nutrient limitations. Further, the N:P ratio of the vegetation may be directly used to determine the nature of nutrient limitation on a community level (Koerselman, Meuleman 1996). Additionally, the abundances of plant species in a community may be affected in some extent by the N:P ratio. For instance, some plant species are able to acquire N from the atmosphere through bacterial symbiosis or P plant uptake is promoted by mycorrhizal symbiosis. Therefore, the growth of these species may not be restricted by a potential nutrient deficiency.

**Thus, the N:P ratio in water, pore water, substrate and vegetation is frequently determined in environmental studies in order to obtain information about the nutrient status and nutrient cycling or to detect biogeochemical changes by external natural or human impacts.**

#### ELABORATING THE EXPERIMENT

##### 1. General description

The N/P ratio is determined in an aquarium and adjusted to a preferable value, if it promotes algae growth.

## 2. Experimental design

The quantification of the atomic N:P ratio in an aquaria system and add nitrate or phosphate in order to improve the water quality by the reduction of algae growth.

## 3. Materials and equipment

For water sampling, an aquarium with visible algae growth is advantageous. Algae bloom arises frequently in aquariums, if unfavourable changes in the nutrient composition appear. For the quantification of the nitrate and phosphate content use a chemical determination kit. Adjustment of the N:P ratio is performed by  $\text{KNO}_3$  or  $\text{K}_2\text{HPO}_4$  additions and the pH is determined by a pH meter or by pH indicator strips.

### Phosphorus and nitrogen determination methods for detailed environmental studies

Phosphorus content can be measured very precisely by a photometric method (Murphy and Riley 1962) and the N content is frequently determined by a C/N elemental analyzer.

The determination of organically bound nutrients is performed by previous combustion or chemical oxidation (Koroleff 1983, Purcell, King 1996) of the plant material in order to convert the organic P to orthophosphate and the organic N to nitrate prior to analysis. For the determination of phosphorus in sediment a number of different extraction procedures are available in order to discriminate between organic and inorganic P (Legg, Black 1955) and to determine bioavailable P (Morgan 1941). Further, sequential extraction methods enable the measurement of calcium and iron/alumina bound P pools (Kurmies 1972) or the quantification of particular phosphorus minerals and adsorbed P (Oxmann *et al.* 2008).

## 4. Experimental description

Determine the nitrate and phosphate content (in mg/l) according to the suppliers manual. Prepare stock solutions of  $\text{KNO}_3$  and  $\text{K}_2\text{HPO}_4$ . Stock solutions of 100 g/l  $\text{KNO}_3$  and 20 g/l  $\text{K}_2\text{HPO}_4$  are recommended. Determine the pH value of the water and calculate the volume of the water in the aquarium.

Note, that other nutrients can also be growth limiting factors, such as Fe. For example, iron phosphate or other relatively insoluble iron compounds can precipitate. Other nutrient

compounds may be additionally measured and added, if the equipment is available. Iron is maintained in an available form by iron fertilizers through complexation with a chelating agent.

### Calculations:

- The molar contents (mmol/l) of nitrate and phosphate are calculated as follows:
  - Phosphate content (mg/l) / molar weight of phosphate (94,972 mg/mmol);
  - Nitrate content (mg/l) / molar weight of nitrate (62.005 mg/mmol).
- The molar contents of nitrate and phosphate are equal to the molar contents of nitrogen and phosphorus, respectively.
- The molar content of nitrogen is divided by the molar content of phosphorus.

Check your calculations by using the **Table 1**.

**Table 1.** *Elemental N:P ratios at varying phosphate and nitrate contents.*

Phosphate (mg/l)	Nitrate (mg/l)					
	5	10	15	20	25	30
<b>0.5</b>	<b>15</b>	31	46	61	77	92
<b>1</b>	8	<b>15</b>	23	31	38	46
<b>1.5</b>	5	<b>10</b>	<b>15</b>	<b>20</b>	26	31
<b>2</b>	4	8	<b>11</b>	<b>15</b>	<b>19</b>	23
<b>2.5</b>	3	6	9	<b>12</b>	<b>15</b>	<b>18</b>
<b>3</b>	3	5	8	<b>10</b>	<b>13</b>	<b>15</b>

### Adjusting the N/P ratio:

According to the elemental N/P ratio of 16, the ratio of the nitrate/phosphate concentration is ca. 10.

If the water contains an elevated level of phosphate in comparison to nitrate, e.g. 1 mg/l of phosphate and 5 mg/l of nitrate, the nitrate content has to be increased accordingly (10 mg/l). Increase the phosphate content, if the nitrate concentration is elevated. Calculate the amount of the stock solution that is required to adjust the N/P ratio by taking the volume of the aquarium into account and note that you add the salts ( $\text{KNO}_3 = 101.103$  g/mol;  $\text{K}_2\text{HPO}_4 = 174.176$  g/mol). Add the fertilizer and subsequently determine the N/P ratio again. An N:P ratio between 10 and 20 is recommended to reduce the growth of algae (see table, numbers in bold).

Check and adjust the N:P ratio during the next month and examine the effect of the nutrient adjustment.

## 5. Organizing the data

Prepare a table (see **Table 2**) including the data of the measurements, the added nutrient amounts and changes in visible algae abundances.

**Table 2.** *Table of the experiment.*

	Day					
	1	2	5	10	20	30
<b>Before add.:</b>						
N (mg/l; mmol/l)						
P (mg/l; mmol/l)						
Atomic N/P						
<b>Add. Stock solution (denote N or P and ml)</b>						
<b>After add.:</b>						
N (mg/l; mmol/l)						
P (mg/l; mmol/l)						
Atomic N/P						
pH						
Visible algae abundances						
Further comments						

## 6. Analyzing the results

Prepare a diagram of the measured time series including the nutrient contents, N/P ratios and pH values.

## 7. Discussion

Discuss the chemical and physicochemical changes in relation to the nutrient inputs and observed algae abundances.

## REFERENCES

- Anderson D.M., Glibert P.M., Burkholder J.M. 2002. Harmful algal blooms and eutrophication: nutrient sources, composition, and consequences. *Estuaries* 25:704-726.
- Boesch D., Hecky R., O'Melia C., Schindler DW., Seitzinger S. 2006. Eutrophication of Swedish Seas. Final Report, Swedish Environmental Protection Agency, Stockholm, Sweden.
- Dent D.L. 1986. Acid sulphate soils: a baseline for research and development. ILRI publications 39, Wageningen.
- Hutchison GE. 1973. Eutrophication. *American Scientist* 61:269-279.
- Koerselman W., Meuleman A.F.M. 1996. The vegetation N:P ratio: A new tool to detect the nature of nutrient limitation. *Journal of Applied Ecology* 33:1441-1450.
- Koroleff F. 1983. Determination of phosphorus. *In*: K. Grasshoff, M. Ehrhardt and K. Kremling (eds). *Methods of Seawater Analysis*. Verlag Chemie, Weinheim, Deerfield Beach, FL, Basel. 125-139 pp.
- Kurmies B. 1972. Zur Fraktionierung der Bodenphosphate. *Die Phosphorsäure* 29:118-149.
- Lake Winnipeg Stewardship Board. 2006. Reducing nutrient loading to Lake Winnipeg and its Watershed: Our Respective Responsibility and Commitment to Action. Report to the Minister of Water Stewardship December 2006.
- Legg J.O., Black C.A. 1955. Determination of organic phosphorus in soils. 2. Ignition method. *Soil Science Society of America Proceedings* 19:139-143.
- Lindsay W.L. 1979. *Chemical equilibria in soils*. John Wiley and Sons, New York.
- Lockaby B.G., Walbridge M.R. 1998. Biogeochemistry. *In*: M.G. Messina, W.H. Connor (eds). *Southern forested wetlands - ecology and management*. Lewis, Boca Raton. 149-172 pp.
- Morgan M.F. 1941. *Chemical Soil Diagnosis by the Universal Soil Testing System*. Connecticut Agricultural Experiment Station Bulletin. 450 pp.
- Murphy J, Riley JP (1962) A modified single solution method for the determination of phosphate in natural waters. *Analytica Chimica Acta* 27:31-36.
- Purcell L. C., King C. A. 1996. Total nitrogen determination in plant mineral by persulfate digestion. *Agronomy Journal* 88:111-113.
- Redfield A.C. 1934. On the proportions of organic derivations in sea water and their relation to the composition of plankton. *In*: R.J. Daniel (ed.). *James Johnstone Memorial Volume*. University Press of Liverpool. 177-192 pp.
- Oxmann J.F., Pham Q.H., Lara R.J. 2008. Quantification of individual phosphorus species in sediment: A sequential conversion and extraction method. *European Journal of Soil Science* DOI 10.1111/j.1365-2389.2008.01062.x.



## 4. EFFECTS OF NUTRIENT AND LIGHT ENRICHMENT ON PHYTOPLANKTON GROWTH.

### Chapter objectives

To determine the effects of nutrient and light enrichment on the growth of natural phytoplankton communities.



*Leptocylindricus danicus* (photo S.Muzavor)

### EH principle: 1 – quantification of threats

#### INTRODUCTION

Alterations of freshwater flow regimes and increasing eutrophication lead to alterations in light availability and nutrient loading into adjacent estuaries and coastal areas. Phytoplankton community respond to these changes in many ways. Harmful phytoplankton blooms, for instance, may be a consequence of changes in nutrient supply, as well as the replacement of some phytoplankton species (like diatoms, that contribute for the development of large fish and shellfish populations) by others (like cyanobacteria, that may be toxic and represent an undesirable food source for higher trophic levels). Nutrient and light enrichment experiments allow us to understand and predict the effects of eutrophication on the growth of phytoplankton. This is a fundamental tool in water management issues, since it enables the prediction of changes in the phytoplankton community that may be harmful to the whole ecosystem, and the design of mitigation strategies (Zalewski 2000).

#### ELABORATING THE EXPERIMENT

##### 1. General description

Water samples will be collected from the study site and dispensed into polycarbonate bottles. Control bottles containing non manipulated natural phytoplankton communities will be incubated in a tank filled with tap water, to avoid extreme changes in water temperature, and covered with different levels of screens to simulate mean light intensity in the mixed layer ( $I_m$ ). Additional bottles will be enriched with dissolved inorganic nitrogen (N), phosphorus (P) and silicon (Si) and incubated under  $I_m$ . Moreover, bottles will be incubated inside other tank and exposed to  $2 \cdot I_m$ .

Phytoplankton growth response in control bottles and light and nutrient enrichments will be compared. Growth will be evaluated through changes in phytoplankton abundance, using the inverted microscope. If one or several taxa respond significantly to either nutrient or light addition, in relation to the control, it means that growth of those taxa is limited by that resource.

##### 2. Experimental design

Four nutrient enrichment and one light enrichment experiments will be performed. The nutrients to be added are (see **Table 1**):

**N** as nitrate ( $\text{NO}_3^-$ ) – using potassium nitrate ( $\text{KNO}_3$ ),

**P** as orthophosphate ( $\text{PO}_4^{3-}$ ) – using anhydrous potassium dihydrogen phosphate ( $\text{KH}_2\text{PO}_4$ ),

**Si** as silicate ( $\text{Si}(\text{OH})_4$ ) – using sodium hexafluorosilicate ( $\text{Na}_2\text{SiF}_6$ ).

Light intensity ( $I_m$  and  $2 \cdot I_m$ ) will be regulated with the use of different levels of screens. If possible, each experimental treatment should be done in duplicate. Ammonium ( $\text{NH}_4^+$ ) is another important source of N for phytoplankton, so it can be tested as well. Nutrient additions can also be done in combinations (eg. **N+P**; **N+Si**; **Si+P**; **N+P+Si**), given that phytoplankton may sometimes be co-limited by 2 or more nutrients.

**Table 1.** Example of nutrient additions for a nutrient enrichment experiment.

Nutrients	100 mM $\text{NO}_3^-$	100 mM $\text{SiO}_4^{4-}$	100 mM $\text{PO}_4^{3-}$
control	-	-	-
+N	1.5 mL	-	-
+P	-	-	150 $\mu\text{L}$
+Si	-	1.5 mL	-
+NP	1.5 mL	-	150 $\mu\text{L}$
+SiN	1.5 mL	1.5 mL	-
+SiP	-	1.5 mL	150 $\mu\text{L}$
+NPSi	1.5 mL	1.5 mL	150 $\mu\text{L}$

Water samples will be collected from each bottle along the incubation period to analyse phytoplankton abundance and composition. The extent of the experiment (1-6 days) should be adjusted according to phytoplankton overall activity.

### 3. Materials and equipment

#### a) Field work

- 1 L polycarbonate bottles; other non reactive transparent plastic bottles could be used (the length of the experiment depends also on the sample volume used);
- subsurface water sampler (eg. Niskin or Van Dorn bottles); a clean bucket can also be used;
- Secchi disk;
- thermometer;
- refractometer or salinity probe.

#### b) Incubation

- Two tanks filled with tap water (to avoid drastic changes in water temperature);
- Several layers of screen to cover the tanks, to simulate 1m and 2\*1m (see **Photo 1**);
- A more expensive alternative is a chamber/room with controlled light and temperature to incubate the bottles.



**Photo 1.** *Incubation tank.*

#### c) Nutrient solutions

Prepare the following stock solutions:

- 100 mM N – dissolve 1.011 g  $\text{KNO}_3$  in 100 mL distilled water;
- 100 mM P – dissolve 1.361 g  $\text{KH}_2\text{PO}_4$  in 100 mL distilled water;
- 100 mM Si – dissolve 1.881 g  $\text{Na}_2\text{SiF}_6$  in 100 mL distilled water;

- now dilute each stock solution to obtain the working solutions (eg. 500  $\mu\text{M}$ , 100  $\mu\text{M}$ ) that will be added to the bottles. The concentration of the working solutions depends on the concentration you want to obtain in the bottles after addition.

#### d) Phytoplankton analysis

- inverted microscope;
- Utermohl's settling chambers (sedimentation cylinder, bottom-plate chamber, top plates);
- Lugol's iodine solution (dissolve 100 g potassium iodide with 1 L distilled water; add 50 g crystalline iodine and 100 mL glacial acetic acid);
- small glass bottles for sample collection and preservation.

#### e) Statistical and graphic software

- Computer and data sheet organizer.

#### f) Safety information

*Check the weather forecast before going to the field. Use appropriate clothing. Do not walk into deeper water or enter a boat wearing your water proof boots. Beware of touching electric devices with your hands wet. Be very careful when using all electric equipments.*

### 4. Experiment description

#### a) Field work

At the sampling site, collect water with the subsurface water sampler at the desired depth. Measure water temperature, salinity and Secchi disk depth. Secchi depth ( $Z_s$ ) is a measure of water turbidity and will be used to estimate vertical light extinction coefficient, according to equations 1 or 2, in case of non-turbid ( $Z_s > 5$  m; [Poole, Atkins 1929](#)) and turbid aquatic systems ( $Z_s < 5$  m; [Holmes 1970](#)), respectively.

You may use a mesh to eliminate some zooplankton, but the larger phytoplankton will probably be eliminated as well. The bottles should be kept in cold and dark conditions during transportation to the laboratory.

#### b) Nutrient enrichment

Nutrients should be added in excess, meaning that final concentrations in the bottles should be much higher than the concentrations measured in the sampling area (see **Table 1** for an example). Identify each bottle (control, +N, +P, +Si) and add the respective nutrient solution.

**c) Light enrichment**

Average light intensity in the mixed layer ( $I_m$ ) will be estimated as a percentage of light intensity at the surface layer ( $I_0$ ), using values of mixed layer depth ( $Z_m$ ) and vertical light extinction coefficient ( $K_e$ ; (equation 1 and 2, see Annex), according to equation 3 (see Annex). Water column depth could be used as  $Z_m$  in shallow mixed coastal systems. For stratified water bodies, vertical distribution of water temperature and salinity should be analysed during field work in order to determine the mixed layer extension ( $Z_m$ ). Combination of different levels of screen will be used in order to simulate  $I_m$  and  $2 \cdot I_m$  inside the tanks. Light attenuation of each screen level should be previously known (information usually provided by manufacturer; if not, the attenuation capability of each screen can be measured with a radiometer). For instance, if  $I_m = 0.30 \cdot I_0$ , then the different levels of screen should remove 70% of incoming radiation.

**d) Sampling for phytoplankton**

In 1 L bottles, the experiments will run for 4 days. Collect water samples from each bottle every 24 hours. Samples for phytoplankton enumeration are preserved with Lugol's solution (0.8 mL Lugol + 100 mL water sample).

**e) Phytoplankton enumeration**

Settle preserved water samples using the Utermohl's settling cylinder and chamber (Hasle, 1978). The volume of the cylinder to be used depends on phytoplankton abundance; samples with lower abundance require a larger settling cylinder. Settling time depends on the height of the cylinder, but you can count at least 1 hour for each centimetre of cylinder height (eg. for a cylinder with 5 cm height, settling time is 20 hours). Use the inverted microscope to identify and quantify the abundance of specific phytoplankton groups. You can try to distinguish between diatoms, green algae, cyanobacteria, dinoflagellates, euglenophytes, and other flagellates, using phytoplankton identification manuals (eg. John *et al.* 2002, Tomas 1997).

**5. Organizing the data**

For each phytoplankton group considered, create a table with  $n+1$  columns where  $n$  represents the number of different experimental treatments including controls. The first column corresponds to the sampling time (days) and the other columns correspond to the abundance of a specific phytoplankton group under the  $n$

different experimental treatments. Then, design a xy graph for each group, where xx axis represents the sampling time (days) and yy axis the specific phytoplankton abundance. This way you can visually evaluate the effects of nutrient and light enrichments, by comparison with the control. Then, you should fit an exponential (equation 4, see Annex) or linear (equation 5, see Annex) function to each data set in order to calculate phytoplankton net growth and its standard error. If the growth is exponential (a common occurrence) use only the period of exponential growth. You should also apply statistical tests to determine whether there are significant differences between the growth rate of control and manipulated treatments.

**6. Analysing the results**

1. Are net phytoplankton growth rates in the manipulated treatments statistically different from the control?
2. Do net phytoplankton growth rates under light and nutrient enrichment statistically differ?
3. Was phytoplankton growth in the control positive?
4. Which treatment showed the highest differences in relation to the control?
5. Were the growth rates equal in all treatments?

**7. Discussion**

1. How did N and P enrichment affect the phytoplankton community?
2. How did Si enrichment affect the diatoms?
3. If there was enhanced growth of non-diatom cells with Si enrichment, what caused that growth?
4. Was the phytoplankton community nutrient-limited? By which nutrients?
5. What factors can explain phytoplankton growth, other than nutrient enrichment?
6. If you had to do this experiment again, what would you change?

**REFERENCES**

1. Hasle G.R. 1978. Settling: the inverted-microscope method. *In*: A. Sournia (ed.). *Phytoplankton Manual*. UNESCO. 88-96 pp.
2. Holmes R.W. 1970. The Secchi disc in turbid coastal waters. *Limnology and Oceanography* 15:688-694.
3. John D.M., Whitton B.A., Brook A.J. 2002. *The Freshwater Algal Flora of the British Isles*. Cambridge University Press. 702 pp.

4. Poole H.H., Atkins W.R.G. 1929. Photoelectric measurements of submarine illumination throughout the year. *Journal of the Marine Biological Association of the United Kingdom* 16:297-325.
5. Tomas C.R. 1997. *Identifying Marine Phytoplankton*. Academic Press. 858 pp.
6. Zalewski M. 2000. Ecohydrology-the scientific background to use ecosystem properties as management tools toward sustainability of water resources. Guest Editorial in *Ecological Engineering* 16:1-8.

## ANNEX

### Formulas:

- equation 1  $K_e = 1.7/Z_s$   
 equation 2  $K_e = 1.4/Z_s$   
 equation 3  $I_m = I_0 \cdot (1 - e^{-K_e \cdot Z_m}) \cdot (1/K_e \cdot Z_m)$   
 equation 4  $y = e^{ax}$   
 equation 5  $y = ax + b$

### Legend:

- $Z_s$  – Secchi depth (m)  
 $K_e$  – extinction coefficient ( $m^{-1}$ )  
 $I_m$  – mean light intensity in the mixed layer ( $\mu\text{Einstein } m^{-2} s^{-1}$ )  
 $I_0$  – light intensity at the surface ( $\mu\text{Einstein } m^{-2} s^{-1}$ )

## 5. CAN ENZYMES SUPPLY CYANOBACTERIAL BLOOMS?

### Chapter Objectives

Demonstrate the way how the enzymatic mechanism of phosphorus recycling in water works. Present the role of internal nutrients supply for phytoplankton development and cyanobacterial blooming.



Cyanobacterial bloom (photo M.Tarczynska)

### EH principle: 1 – quantification of threats

#### INTRODUCTION

Development of cyanobacteria in water depends, among others, on nutrition conditions in water. The most important nutrition elements are phosphorus (P) and nitrogen (N), which are available for cyanobacteria only in form of inorganic ions:  $\text{PO}_4^{3-}$ ,  $\text{NO}_3^-$ ,  $\text{NH}_4^+$  (Reynolds, 1984). P and N incorporated into organic compounds to be liberated as an inorganic must be processed by hydrolytic enzymes first (Turpin 1988).

Enzymes are catalysts of biochemical reactions. They are substrate specific, i.e. they react only with selected group of compounds. One of the enzymes that takes part in transformation of organic phosphorus in water is alkaline phosphoesterase, usually called phosphatase (APA) (E.C. 3.1.3.1.). This enzyme catalyzes hydrolysis of phosphate esters with liberation of orthophosphate ions ( $\text{PO}_4^{3-}$ ) from organic compounds (Jansson *et al.* 1988). APA is released mainly by bacteria and phytoplankton in response to orthophosphate scarcity in water (Siuda 1984, Chróst 1991). Deficiency of easily available orthophosphate is often observed during intensive phytoplankton development, especially while cyanobacterial blooming. In this case APA acts as one of mechanisms of phosphorus regeneration in water which supports phytoplankton growth (Chróst, Overbeck 1987). High activity of the alkaline phosphatase can significantly accelerate formation of cyanobacterial blooms and prolong their appearance due to better nutrients supply (Trojanowska *et al.* 2001).

Activity of APA might be blocked due to:

- 1) lack of the substrate, i.e. phosphoric monoesters in case of phosphatase;
- 2) inhibitors presence, such as:  $\alpha$ -phenylalanine, other amino acids, urea.

3) incorporation into humic acids structure,  
4) abiotic disturbance of the environment, such as extreme hydrological conditions (McComb *et al.* 1979, Siuda 1984).

**Thus, reduction of the alkaline phosphatase activity in water to avoid cyanobacterial blooming is potentially possible due to skilful manipulation of selected ecological and hydrological factors (Zalewski *et al.* 2000).**

#### ELABORATION OF EXPERIMENT

##### 1. General description

Activity of the enzyme: alkaline phosphate, in response to  $\text{PO}_4^{3-}$  limitation will be measured in three different variants of P nutrition in water. Lake water with 3 different concentrations of orthophosphate will be incubated with identical amount of phytoplankton. In variants, where  $\text{PO}_4^{3-}$  nutrition does not meet the phytoplankton demand, it is expected that alkaline phosphatase is going to be released to water by phytoplankton and bacteria. Alkaline phosphatase activity will be measured fluorometrically (with MUFPP) or spectrophotometrically (with p-NPP) (Hoppe, 1983, Huber, Kindby, 1984). High activity of the enzyme cause the increase of  $\text{PO}_4^{3-}$  concentration in water, which will be measured with a spectrophotometer (Golterman 1973). Higher availability of P may stimulate phytoplankton growth, which amount will be expressed in chlorophyll-a concentration. Chlorophyll-a will be measured in vivo with a fluorometer or will be processed for spectrophotometric analysis (Holm-Hansen 1978, Madden, Day 1992). Changes in dissolved oxygen concentration, pH and temperature in water will be measured with the electrodes set. Supplementary analyses of total amount of bacteria in water might be provided with

fluorescent microscope in DAPI stained samples (Porter, Feig 1980).

## 2. Experimental design

Experiment design considers 3 variants of different  $\text{PO}_4^{3-}$  concentrations: natural of lake water used in control option,  $\sim 20 \mu\text{g dm}^{-3}$  and  $\sim 200 \mu\text{g dm}^{-3}$ . This is to demonstrate how the enzymatic mechanism of P release works in different levels of orthophosphate quantity. Each option is prepared in triplicates in at least  $10 \text{ dm}^{-3}$  glass container (9 containers in total should be prepared).

Water taken from a lake should be filtered first thru plankton net of  $50 \mu\text{m}$  mesh size to remove zooplankton, that graze the phytoplankton and could be a source of underestimation of chlorophyll-a during the experiment. Next, water should be filtered again thru plankton net of  $20$

$\mu\text{m}$  mesh size to remove phytoplankton. Phytoplankton should be gently collected in a container for utilization while preparing 3 variants of experiments (Figure 1). After the filtration initial measurement of orthophosphate concentration in water should be made. Once you know the concentration you are ready to start preparation of  $30 \text{ dm}^{-3}$  of water for each variant by dilution lake water with distilled water to get low  $\text{PO}_4^{3-}$  concentration ( $\sim 20 \mu\text{g dm}^{-3}$ ) and by addition of  $\text{K}_2\text{HPO}_4$  to get the highest one ( $\sim 200 \mu\text{g dm}^{-3}$ ). Fill the containers with water and add gently of collected phytoplankton in identical amount to each container. In the starting point of the experiment all the parameters should be analysed.

Containers should be left for incubation well illuminated for 2 weeks. Samples for analyses should be taken at least every second day.

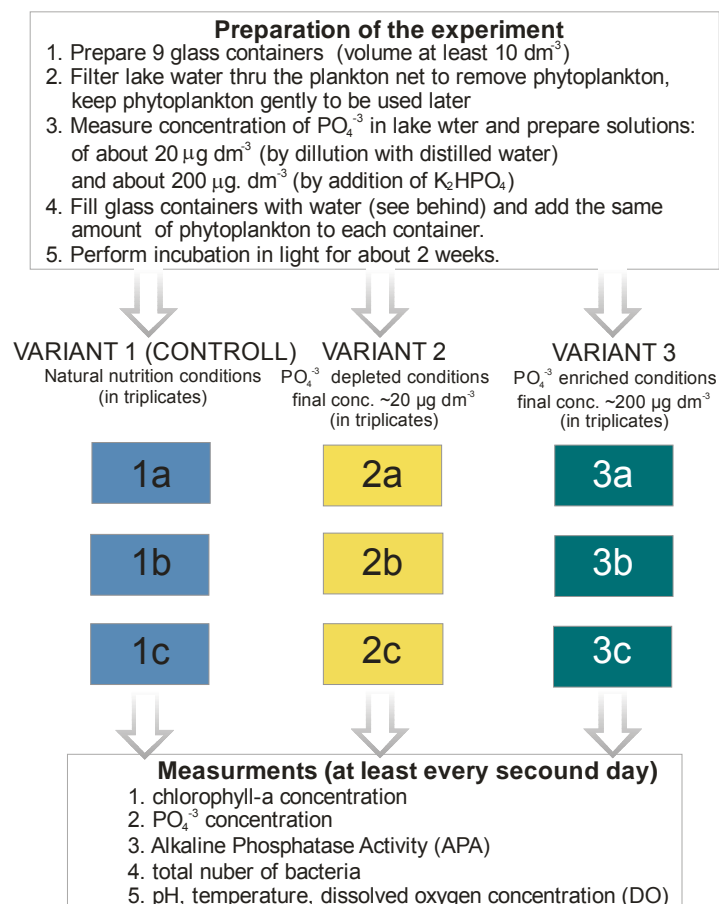

**Figure 1.** The scheme of experiment design for demonstration how APA supports phytoplankton blooms.

Before starting analyses of APA,  $P-PO_4^{-3}$ , chlorophyll-*a* be sure to prepare calibration curves if needed. Additionally, phytoplankton species composition with microscopic method may be applied once a week.

### 3. Materials and equipment

#### a) Field experiments

You will need materials and equipment to collect water and to measure basic physico-chemical water parameters:

- boat and water sampler to collect water;
- baskets and containers for water collecting and to transport it to the lab;
- plankton net with 50  $\mu\text{m}$  mesh size to remove zooplankton;
- plankton net with 20  $\mu\text{m}$  mesh size to remove phytoplankton – important: removed phytoplankton should be collected in a container since it is going to be used in the experiment;
- container to hold gently phytoplankton removed and to transport it to laboratory;
- probe to measure temperature, pH and DO in water;
- clothing: water proof boots to walk on the margins, water proof jacket.

#### b) Laboratory experiments

You will need to use a wet lab, preferably with aquaria systems or glass containers (**Photo 1**).



**Photo 1.** Preparation of the experiment.

Basically you will need:

- 9 glass containers for incubation of water with phytoplankton: 3 for each variant;

- calibrated flask for measurement of the amount of phytoplankton added to each variant of the experiment;
- vacuum pumps for water prefiltration;
- Whatmann glass fiber filters GF/F for chlorophyll-*a* analyses and prefiltration of water for  $PO_4^{-3}$  analyses;
- pipettes, vials, laboratory glass, etc. for chemical analyses;
- fluorometer or spectrophotometer for chlorophyll-*a* determination and appropriate reagents (depend on the selected method);
- spectrophotometer for determination of  $PO_4^{-3}$  together with appropriate reagents (depend on method used) and calibration curve for calculation of the results (if needed);
- spectrophotometer or fluorometer for APA determination as well as appropriate reagents (substrate: p-NPP or MUFP, buffers, standards: p-NP or MUF, depend on method used) and calibration curve for calculation of the results;
- fluorescent microscopy (magnification at least 10x100), DAPI solution, black carbonate membrane filters (0,2  $\mu\text{m}$ ,  $\phi$  25mm), filtration apparatus and low pressure vacuum pump, non fluorescent immersion oil;
- additionally for examination of phytoplankton species composition: microscope (magnification 10x40), chamber for phytoplankton counting, keys for phytoplankton classification;
- protective laboratory clothing to avoid direct contact with insecure substances.

#### c) Data analysis

- computer;
- data sheet organizer (sample copy in Annex);
- basic calculation and graphic software;
- guide for statistical analyses of environmental data (if needed).

#### d) Safety information

*Check the weather forecast before going to the field. Use appropriate clothing. Do not walk into deeper water or enter a boat wearing your safety jacket. Be very careful when using all electric equipment, beware of touching electric devices with your hands wet. Use protective clothing while working in laboratory. Avoid direct contact of your skin with bacteria or cyanobacteria.*

## 4. Organizing the data

### Data sheets

Proposed data sheet for experiment is presented in the Annex. Prepare four calculation sheets. Three of them will be used for typing data collected directly from the analyses of samples collected while the experiment runs, i.e. one sheet for each variant. This sheets will be used for testing variables between replicates and for calculating the average value for each parameter, according the rules specified below. Next, the average values will be moved to the fourth sheet containing final data (see **Table 1** and **Table 2** in **Annex**). This sheet will be used for final statistical analyses, indication of trends over time and comparison of changes between different parameters over a time.

### Basic statistical analysis

The results of experiment need very basic statistical analyses.

Perform the variability analysis within the replicates in each variant, calculate the standard deviation (SD) for each sampling event for each parameter. If any of replicates show trends or values significantly distinct from others (SD exceed the value of statistical error) this replicate should not be taken into account and such data should be rejected from statistical analyses or analysed separately. Calculate average values and SD of each parameter from replicates to enable demonstration of trends and to compare changes between variants. Higher SD value than the statistical error confirm existence of trends over a time. The analyse should be repeated for each parameter.

Compare average values of alkaline phosphatase activity with  $\text{PO}_4^{-3}$ , chlorophyll-*a*, total number of bacteria as well as  $\text{PO}_4^{-3}$  and chlorophyll-*a* and Chlorophyll-*a* and DO in three variants of experiment.

All variables should be first transformed when appropriate to approximate normal distribution. There could be applied typical transformation  $\log_{10}(x+1)$ . To check if there are statistically significant relationships between measured variables calculate Pearson Correlation Coefficient (*r*) between:

1. APA and  $\text{PO}_4^{-3}$ .
2. APA and chlorophyll-*a*.
3. APA and total number of bacteria.
4. Chlorophyll-*a* and  $\text{PO}_4^{-3}$
5. Chlorophyll-*a* and DO.

### Making graphs

For further analysis of data and final conclusions prepare following graphs for each variant:

1. Changes of APA,  $\text{PO}_4^{-3}$  and chlorophyll-*a* concentrations over a time.
2. Changes of pH, DO and temperature over a time.
3. Regression of APA vs.  $\text{PO}_4^{-3}$ .
4. Regression of APA vs. chlorophyll-*a* concentration.
5. Regression of APA vs., total number of bacteria.

Use calculated average values for preparing graphs for each variant of the experiment.

## 5. Analysing the results

Formulate final conclusions of the experiment answering following questions on the basis of data obtained and graphs prepared:

1. Was there a significant difference in APA activity between variants of the experiment?
2. What level of  $\text{PO}_4^{-3}$  promoted release of APA in the experiment?
3. Was there a response of  $\text{PO}_4^{-3}$  concentration on higher enzyme activity?
4. Was there a difference in phytoplankton development and chlorophyll-*a* concentrations among variants of the experiment?
5. Was enzyme supporting phytoplankton development?
6. Was enzyme activity dependent on number of bacteria or rather chlorophyll-*a*?
7. For a what extend and in what periods the enzymatic activity might support cyanobacterial blooms forming?
8. Propose how to control the alkaline phosphatase activity in water to avoid cyanobacterial blooming.
9. Are there other parameters that could be helpful for further interpretation of the experiment results?
10. If you have to do this experiment again, what would you change? Why?

## 6. Discussion

Discuss the obtained results with literature concern the topic.

## REFERENCES

1. Chróst R.J. 1991. Environmental control of the synthesis and activity of aquatic microbial enzymes. *In*: R.J. Chróst (ed.). Microbial enzymes in aquatic environments. Springer-Verlag, New York, Berlin, Heidelberg. 29-59 pp.
2. Chróst R., Overbeck J. 1987. Kinetics of alkaline phosphatase and phosphorus availability for phytoplankton and bacterioplankton in Lake Plubsee (North German Eutrophic Lake). *Microbial Ecology* 13:229-248.
3. Golterman H.L. 1973. Vertical movement of phosphate in freshwater. *In*: E.J. Griffith, A. Betton, J.M. Spencer, D.T. Mitchell (eds). Environmental phosphorus handbook. John Wiley & Sons, New York, London, Sydney, Toronto: 509-538 pp.
4. Holm-Hansen O. 1978. Chlorophyll-a determination: improvements in methodology. *Oikos* 30:438-447.
5. Hoppe 1983. Significance of exoenzymatic activities in ecology of brackish waters: measurements by means of metylumelliferyl substrates. *Marine Ecology Progress Series* 11:299-308.
6. Huber A.L., Kindby D.K.. 1984. An examination of the factors involved in determining phosphatase activities in estuarine water: Analytical procedures. *Hydrobiologia* 11:3-11.
7. Jansson M., Olsson H., Petterson K. 1988. Phosphatases: origin, characteristics and function in lakes. *Hydrobiologia* 170:157-175.
8. Madden C.J., Day J.W. 1992. An instrument system for high-speed mapping of chlorophyll-a and the physical-chemical variables in surface water. *Estuaries* 15:421-427.
9. McComb R. B., Browers G. N., Posen S. 1979. Alkaline phosphatases. Plenum Press, NY. 986 pp.
10. Porter K.G., Feig Y.S. 1980. The use of DAPI for identifying and counting aquatic microflora. *Limnology and Oceanography* 25(5):943-948.
11. Reynolds C.S. 1984. The ecology of freshwater phytoplankton. Cambridge University Press, Cambridge. 384 pp.
12. Siuda W. 1984. Phos[phatases and their role in organic phosphorus transformation in natural waters. A review. *Polish Archiv of Hydrobiology* 31(3):207-233.
13. Trojanowska A., Tarczyńska M., Wagner I., Romanowska-Duda Z., Zalewski M. 2001. The importance of phosphatase activity as compensatory mechanism for phytoplankton primary production in lowland reservoir (Polnad). *Proceedings of the 9th World Lake Conference, Otsu Japan.* 3C/D-P83, 572-575.
14. Turpin D.H. 1988. Physiological mechanisms in phytoplankton ecology. *In*: C.D. Sandgren (ed.). Growth and reproductive strategies of freshwater phytoplankton. Cambridge University Press, New York. 399-433 pp.
15. Zalewski M., Wagner-Lotkowska I., Tarczyńska M. 2000. Ecohydrological approach for elimination of toxic algal blooms in lowland reservoir. *Verb. Internat. Verein. Limnol.* 27:3176-3183.



## 6. WHICH ARE THE PARAMETERS THAT CAN CONTROL BLOOMS EVENTS IN THE LAGOONS?

### Chapter Objectives

To demonstrate how the variability of different parameters controls the development of algal blooms in a lagoon.



Coastal lagoon, Greece (photo U. Dussling)

**EH principle: 1 – identification and quantification of processes**

### INTRODUCTION

Coastal lagoons are complex natural ecosystems easily affected by pollution and other human activities, leading to environmental degradation (Miller *et al.* 1990). Lagoon phytoplankton dynamics, and eventually bloom events, appear influenced by mass transport (advection and dispersion), exogenous environmental factors (as water temperature and light extinction in the water column) and interactive biochemical kinetics, involving the available nutrients (Beck 2005). The molar ratio of nutrient delivery to coastal lagoons is important, since it determines the element that controls phytoplankton production and the species of algal community, which could be developed (Conley 1999).

Studies on nutrient uptake kinetics have pointed out that ambient molar ratios of dissolved nitrogen (N) and phosphorus (P) (N:P ratio) determines potential N or P limitation on phytoplankton growth (Redfield *et al.* 1963). If  $N:P < 16$  then N is the limiting nutrient, while if  $N:P > 16$  then P limits bloom growth.

**This exercise presents a comprehensive set of experiments to assess the impact of various environmental factors on lagoon phytoplankton development.**

### ELABORATING THE EXPERIMENT

#### 1. General description

Aim of the experiment is to compare the evolution of an algae bloom (increase of number of algae cells) and the fluctuation of the dissolved oxygen concentration in the aquarium, when different species are cultured under

different salinities, temperature or even under different light/dark cycles.

The experiment set can be also used in order to change one or more of the above parameters.

#### 2. Experimental design

50 aquariums of 10 to 20 l are required for these cultures. Five sets of seven to ten aquariums each, will be prepared (**Table 1**). Then, in each aquarium of each set, different nutrients molar ratios will be established (**N:P=10/1, 12/1, 14/1, 16/1, 18/1** etc.). The first two sets will be used for the culture of two different species and will have constant temperature and salinity (15 and 20°C). The third set will keep temperature conditions constant, experimenting with salinity change from 15 to 25 psu. In set 4, water temperature will be altered from 10 to 20°C. The fifth set will be used as control and will be the same as in set 1, but without any species cultivation.

The water temperature for cultures maintenance should ideally be as close as possible to the organisms' collection temperature. To control the temperature of the cultures, 50 thermostats are required, one for each aquarium. Apart from water temperature of the culture, it is also preferable to maintain stable the air temperature of the laboratory, where the aquariums are placed; an ambient room temperature is generally acceptable for culturing purposes. For this reason an air-conditioning system, efficient to maintain constant laboratory's temperature is required.

Natural light is usually sufficient to maintain cultures under laboratory conditions. However, the exposure of cultures to direct sunlight may damage the cells. Artificial lighting by fluorescent bulbs could be used for culture maintenance and

experimental purposes. Light quality depends on the type of bulb used, the most common types being “cool white” and “daylight” bulbs. Different **light/dark** cycles, according to the season, will be used during the experiment. In order to maintain a constant light/dark cycle and have the ability to change the ratio of light and dark, thus simulating different seasons, a light control system is required to be installed in the laboratory.

The aeration and mixing of the culture will be obtained using air pumps, with a rate kept constant during the experiment (see **Photo 1**).



**Photo 1.** *Experiment conditions.*

An **UV** system is required for the sterilization of the equipment, preventing contamination by unwanted organisms and further eliminating unwanted chemicals.

SET	Algae species	Salinity	Temperature	
1	A species	15	20	7-10 aquariums with different ratio of <b>N:P</b> concentration each
2	B species	15	20	
3	A species	25	20	
4	A species	15	25	
5	Control	15	20	

Finally, continuous monitoring of the culture in terms of dissolved oxygen, salinity, temperature, pH, light and nutrients concentration is needed, to maintain a favorable environment for algae to grow (**Table 2**, see **Annex**).

Self-recording instrumentation installed to the aquariums achieves continuous monitoring. In order to control the algae biomass in each aquarium, the chlorophyll concentration will be measured.

### 3. Materials and equipment

#### a) Field experiments

You will need materials and equipment to collect water, phytoplankton and to measure environmental water parameters:

- baskets and containers for water collection and transport to the lab;
- small phytoplankton-net that will be towed from a boat for phytoplankton sampling;
- containers with oxygen pump to place and transport the phytoplankton collected;
- probe to measure the water environmental parameters;
- clothing: water proof boots, water proof jacket.

#### b) Laboratory experiments

You will need materials and equipment to culture phytoplankton and to monitor the different parameters of the cultures.

Basically you will need:

- 50 aquariums;
- 50 thermostats;
- air-conditioning system;
- air pumps;
- light control system and fluorescent bulbs;
- monitoring systems (dissolved oxygen meter, salinity meter, temperature, pH meter, chlorophyll meter, lux meter);
- photometer for nutrients determination;
- kits for nutrients determination (consider a preliminary analysis to choose the adequate range);
- UV radiation system for sterilization;
- microscope;
- Petri dishes for cell counting;
- hand counter.

#### c) Data analysis

- computer.
- data sheet organizer.
- basic graphic software.

#### d) Safety information

*Check the weather forecast before going to the field. Use appropriate clothing. Do not walk into deeper water or enter a boat wearing your water proof boots. Beware of touching electric devices with your hands wet. Be very careful when using all electric equipments.*

### 4. Experiment description

During the experiment two different algae species will be cultured. These species will be

exposed to different conditions in terms of salinity, temperature and nitrogen and phosphorus concentrations. In order to simulate phytoplankton growth conditions, a simulation of the dark/light cycle of each season for the whole duration of the experiment will take place. Each experiment lasts for three weeks and the daily monitoring (at exactly the same hour of the day) of the above described environmental parameters is needed.

## 5. Organizing the data

### Data calculation

A series of tables will be produced after the implementation of each experimental set. These tables could be inserted in MS Excel to allow results intercomparison and diagrams production. An example for data organization in each experiment is shown in **Table 2 (Annex)**.

The formulas given in **Annex** will allow to calculate the phytoplankton growth rates as a function of temperature (**equation 1ab**) and nutrients (**equation 2**).

### Basic statistical analysis

1. Analysis variability within replicates.
2. Compare phytoplankton growth rates observed under different temperatures, salinities and nutrients.

### What statistical tests use?

Proceed with basic statistics, e.g. T- student.

### Making graphs

Testing graphical representation of the results.

## 6. Analysing the results

Provide questions that represent clues to guide the students in finding the most important results from the experiment:

1. Which N/P ration promotes faster algae growth?
2. In which environmental (T, S) conditions?
3. Which salinity value promotes faster algae growth?
4. Which temperature value promotes faster algae growth?
5. Which algae species seemed to be more sensitive to salinity changes?
6. Which algae species seemed to be more sensitive to temperature changes?
7. There were significant differences in response from different algae species?

## ANNEX

## 7. Discussion

Provide questions that promote the discussion of the results in order that the student can find his/her own conclusions from the experiment:

1. What N/P ration you will choose to control the algae bloom in different salinity and temperature conditions?
2. If the salinity values in the analysed area varied what you think will be the consequence to the studied algae species in terms of abundance.
3. If you have to do this experiment again, what would you change? Why?
4. If you have to do this experiment again, what would you change? Why?

## REFERENCES

1. Beck M.B. 2005. Environmental foresight and structural change. *Environmental Modelling & Software* 20(6):651-670.
2. Conley D.J. 1999. Biogeochemical nutrient cycles and nutrient management strategies, *Hydrobiologia* 289:87-96.
3. Miller J. M., Pietrafesa L.J., Smith N.P. 1990. Principles of hydraulic management of coastal lagoons for aquaculture and fisheries. *In: FAO (ed.) Fisheries Technical Paper 314*. Rome. 88 pp.
4. Redfield A.C., Ketchum B.H., Richards F.A. 1963. The influence of organisms on the composition of sea water. *In: M.N. Hill (ed.). The Sea*. Wiley, New York. 12-37 pp.



## 7. GRAZING IMPACT OF MICROZOOPLANKTON UPON PHYTOPLANKTON.

### Chapter objectives

To demonstrate the importance of microzooplankton as regulator of phytoplankton biomass and production.



*Thalassiosira rotula* (photo S. Muzavor)

**EH principle: 2 – enhancement of ecosystem absorbing capacity**

### INTRODUCTION

Alterations of freshwater flow regimes and increasing eutrophication can lead to alterations in phytoplankton biomass, composition, and growth in estuaries and adjacent coastal waters. Since phytoplankton is the first trophic level of most aquatic foodwebs, these changes can be propagated to other biological compartments, eventually impacting water quality and ecosystem services. However, phytoplankton responses to environmental changes in abiotic variables (e.g., light, nutrients) are additionally controlled by mortality or removal processes (e.g., grazing, horizontal advection and viral lysis). Grazing exerted by microzooplankton, usually dominated by phagotrophic protists, is considered the most relevant phytoplankton mortality factor in most aquatic systems (see Calbet, Landry 2004). In fact, grazing impact of microzooplankton can prevent phytoplankton accumulation in marine systems despite an overall increase in phytoplankton replication rate. By consequence, microzooplankton grazing may minimize problems associated to increased eutrophication and, ultimately, prevent the occurrence of harmful phytoplankton blooms. **Thus, microzooplankton grazing on phytoplankton constitutes a key biological process required to understand and predict relationships between hydrological and biological processes in aquatic ecosystems and to use ecosystem properties to improve water quality and enhance ecosystem services, general principles of the Ecohydrology Concept (Zalewski 2000).**

### ELABORATING THE EXPERIMENT

#### 1. General description

A series of different dilutions of natural water samples with particle-free water from the same source ( $<0.2 \mu\text{m}$ ) are incubated *in situ* or under simulated *in situ* conditions. Changes in phytoplankton biomass in different dilutions are monitored and used to estimate potential instantaneous growth rate of phytoplankton, *in situ* instantaneous growth rate of phytoplankton, and grazing rate exerted by microzooplankton. This experimental strategy, the dilution method (Landry, Hassett 1982, Landry 1993), assumes that phytoplankton instantaneous growth is density independent, that phyto-plankton growth limitation is similar among different dilutions, and that increased dilution will cause a proportional reduction in microzoo-plankton grazing pressure. Estimation of potential instantaneous growth rate of phyto-plankton, *in situ* instantaneous growth rate of phytoplankton, and grazing rate exerted by microzooplankton are based on the coefficients of the regression line fitted to phytoplankton apparent growth rates against dilution factor and on the apparent phytoplankton growth rate in unmanipulated water sample.

#### 2. Experimental design

A series of five dilutions of the water sample with particle-free water sample, collected at the same site, will be prepared (e.g., dilutions 0.125, 0.25, 0.5, 0.75, and 1.0). Dilutions will be enriched with dissolved inorganic macronutrients (N, Si, P). Additionally, an experimental treatment with unmanipulated water will be prepared. All experimental treatments, prepared in duplicate, will be incubated *in situ* or under *in situ* simulated conditions during 24 to 48 h. Chlorophyll a

concentration in each experimental treatment will be measured at the beginning and at the end of the experiment.

### 3. Materials and equipment

#### a) Field work

- subsurface water sampler (eg. Niskin or Van Dorn bottles), a clean bucket could also be used;
- containers for sample transportation to the laboratory;
- Secchi disk;
- Thermometer;
- salinity probe or refractometer.

#### b) Preparation of experimental treatments

- 2 L polycarbonate bottles (14 bottles are needed in case of five nutrient enriched dilutions, an unmanipulated water sample treatment, and a particle free water treatment, all prepared in duplicate); other non reactive transparent plastic bottles could be used; bottles should be large enough to minimize wall effects during incubation but smaller volume bottles will decrease the time needed to prepare particle-free water;
- polycarbonate 0.2  $\mu\text{m}$  filters; other filter types can also be used;
- vacuum pump and filtration equipment;
- tweezers;
- graduated measuring cylinders (to deliver different volumes of samples and particle-free samples);
- glass or plastic flasks to prepare each dilution treatment;
- laboratory film;
- solutions of inorganic macronutrients N, Si and P (e.g., potassium nitrate,  $\text{KNO}_3$ ; anhydrous potassium dihydrogen phosphate,  $\text{KH}_2\text{PO}_4$ ; and sodium hexafluorosilicate,  $\text{Na}_2\text{SiF}_6$ ).

#### c) Incubation

- surface float, anchor and lines for *in situ* incubation;
- outdoor tank filled with tap water and layers of screen to simulate average light intensity in the mixed layer ( $I_m$ ) in case *in situ* incubation is not feasible.

#### d) Chlorophyll a analysis

- fluorometer or spectrophotometer with 1 or 5-cm spectrophotometer cells for chlorophyll a determination;

- GF/F filters (for extractive spectrophotometric analysis only);
- 90% acetone (for extractive spectrophotometric analysis only);
- centrifuge for 15 mL tubes (for extractive spectro-photometric analysis only);
- tubes, ca. 15 mL (for extractive spectrophotometric analysis only);
- vacuum pump, filtration system and tweezers (for extractive spectrophotometric analysis only).

#### e) Statistical and graphic software

- Computer and data sheet organizer.

#### f) Safety information

*Check the weather forecast before going to the field. Use appropriate clothing. Do not walk into deeper water or enter a boat wearing your water proof boots. Beware of touching electric devices with your hands wet. Be very careful when using all electric equipments.*

### 4. Experiment description

#### a) Field work

At the sampling site, collect water with a subsurface water sampler at the desired depth. Measure water temperature, salinity and Secchi depth. Secchi depth is a measure of water turbidity and will be used to estimate vertical light extinction coefficient ( $K_e$ ; see equations 2 and 3, Annex). You may use a mesh to eliminate larger metazooplankton (e.g., 100  $\mu\text{m}$ ) in order to get closer to grazing of phagotrophic protists. Dispense water samples into containers for sample transportation. Sample handling and transportation should avoid drastic temperature changes and light exposure. In addition, all materials used during sample collection, handling and processing should be non-reactive, that is, neither inhibitory nor stimulating for phytoplankton and microzooplankton. Because of the time needed to prepare particle-free water samples, you may consider to collect a water sample and filter it one day, and to collect water again and start up the experiment on the next day.

#### b) Preparation of experimental treatments (dilutions)

Prepare a desired volume of particle-free water sample (< 0.2  $\mu\text{m}$ ) that will be used to dilute non-manipulated water samples. You can accelerate this process by using a previous sequential filtration through 100  $\mu\text{m}$  and 10  $\mu\text{m}$  sized

meshes by gravity. Then, use a vacuum pump and polycarbonate filters (0.2  $\mu\text{m}$  pore size) to prepare particle-free water sample. In practice, filters with a higher pore size (e.g., Whatman GF/F glass fiber filters) or Gelman filter capsules can also be used. Ideally, this filtration process should produce particle free water without added biactive contaminants. Prepare a series of five dilutions of the sample (e.g., 0.125, 0.25, 0.5, 0.75, and 1.0). Consider the dilution factor as the proportion of natural sample. A schematic representation of the experimental treatments is depicted in **Figure 1**.

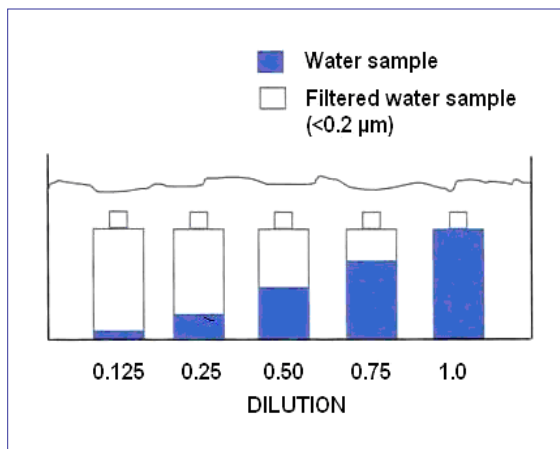

**Figure 1.** Schematic representation of different experimental treatments or sample dilutions. Note that undiluted sample without nutrient additions and particle free water with nutrient additions should also be used.

Use appropriate graduated measuring cylinders to deliver exact volumes of samples and particle-free samples. Add solutions of inorganic macronutrients  $\text{KNO}_3$ ,  $\text{KH}_2\text{PO}_4$ , and  $\text{Na}_2\text{SiF}_6$  to all dilutions (e.g., dilutions 0.125+, 0.25+, 0.5+, 0.75+, and 1.0+). For details of solutions preparation see Domingues, Barbosa 2009 (Chapter 4). Since the concentration of microzooplanktonic organisms, potential sources of inorganic nutrients, varies across dilutions, inorganic nutrients are added in order to ensure that phytoplankton growth limitation is similar among different dilutions. Nutrients should be added in excess and equally to all experimental treatments meaning that final concentrations should be similar to maximum concentrations in the sampling areas. Additionally, prepare a treatment with undiluted water without added nutrients (unmanipulated water sample, dilution 1.0). Prepare each experimental treatment

(dilution 0.125+, 0.25+, 0.5+, 0.75+, 1.0+, and 1.0) in duplicate. Measure chlorophyll *a* concentration (see section 4.d) in the particle-free water and in each experimental treatment and incubate all experimental treatments. Additionally, incubate replicate bottles with particle free water enriched with nutrients. Make sure all the 14 incubated bottles are completely filled, without air bubbles, and tightly closed. Wrap the bottle necks with laboratory film if needed.

### c) Incubation

If feasible, experimental bottles should be incubated *in situ*, using a surface float attached to a tight line and an anchor. If *in situ* incubation is not feasible, incubate all experimental bottles inside an outdoor tank, exposed to a light intensity equivalent to  $I_m$  and natural photoperiod. Average light intensity in the mixed layer ( $I_m$ ) will be estimated as a percentage of light intensity at the surface layer ( $I_o$ ), using values of mixed layer depth ( $Z_m$ ) and vertical light extinction coefficient ( $K_e$ ) according to equation 1 (see Annex). Vertical light extinction coefficients ( $K_e$ ) will be estimated using the Secchi depth values ( $Z_s$ ) according to equation 2 and equation 3 (see Annex) in case non-turbid ( $Z_s > 5$  m, Poole, Atkins 1929) and turbid aquatic systems ( $Z_s < 5$  m, Holmes 1970), respectively. Water column depth could be used as  $Z_m$  in shallow mixed coastal systems. For stratified water bodies, vertical distribution of water temperature and salinity should be analysed during field work in order to determine the mixed layer extension ( $Z_m$ ). Combination of different levels of screen will be used in order to simulate  $I_m$  inside the tanks. Light attenuation of each screen level should be previously known (information usually provided by manufacturer; if not, the attenuation capability of each screen can be measured with a radiometer). For instance, if  $I_m = 0.30 * I_o$ , then the different levels of screen should remove 70% of incoming radiation. For a schematic representation of the incubation setup see Figure 1 in Domingues, Barbosa 2009 (Chapter 4). During the incubation, control the water temperature inside the tank in order to avoid large differences from *in situ* temperature. The duration of the incubation period (24 - 48 hours) should be adjusted according to phytoplankton and microzooplankton overall activity. Measure chlorophyll *a* concentration at each experimental treatment in the end of the experiment.

#### d) Chlorophyll a analysis

Chlorophyll a concentration, a proxy of phytoplankton biomass, will be measured at the beginning and at the end of the experiment in all experimental treatments. Chlorophyll a will be measured semi-quantitatively using *in vivo* fluorometry. Alternatively, you can use an extractive method, such as spectrophotometry, to quantify chlorophyll a concentration. The later implies sample concentration through glass fiber filters (GF/F), pigment extraction with 90% acetone under dark and refrigerated conditions (ca. 24h), and spectrophotometric analysis of chlorophyll a extracts (Parsons *et al.* 1984).

### 5. Organizing the data

#### a) Estimation of phytoplankton growth rates and microzooplankton grazing rates

Phytoplankton apparent growth rates ( $r$ ) in each dilution will be calculated assuming exponential growth according to **equation 4** (see **Annex**) using chlorophyll a concentrations in the beginning ( $Chl_0$ ) and end of the incubation period ( $Chl_t$ ). Create a table with two columns where the first column corresponds to the dilution factor (proportion of sample in each treatment) and the second to apparent growth rate of phytoplankton. Then, design a scatterplot xy graph where xx axis represents dilution factor and yy axis the apparent growth rates of phytoplankton ( $r$ ) in nutrient enriched experimental treatments only (0.125+, 0.25+, 0.5+, 0.75+, 1.0+). Use standard statistical software and fit a linear regression (**equation 5**, see **Annex**) function to this data set. Potential instantaneous growth rate of phytoplankton ( $\mu_0$ ) and grazing rate exerted by microzooplankton ( $g$ ) will be estimated as the intercept (b) and the slope of the regression line (a), respectively (see **equation 5**). Calculate the difference between the apparent phytoplankton growth rates in undiluted samples with (DIL 1.0+) and without nutrient addition (DIL 1.0),  $\Delta r$  (**equation 6**, see **Annex**). *In situ* instantaneous growth rate of phytoplankton,  $\mu$ , will be estimated as the difference between  $\mu_0$  and  $\Delta r$  (**equation 7**, see **Annex**). See **Figure 2** as an example. Use statistical software and estimate the standard errors of all variables. In case prepared dilutions are not close to expected dilutions, either due to non accurately measured volumes or elevated chlorophyll a in particle free water, use corrected dilution values on the xx axis.

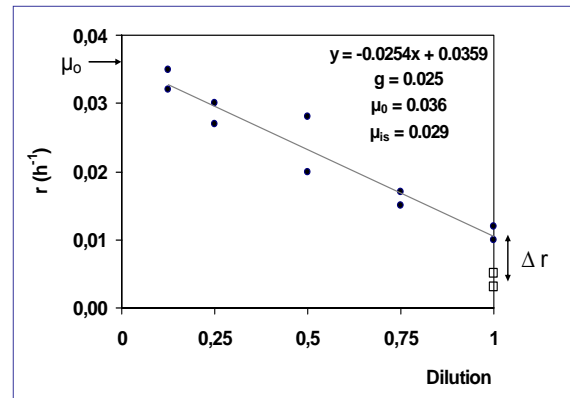

**Figure 2.** Relationship between dilution value and apparent phytoplankton growth rate ( $r$ ) in a typical dilution experiment. Solid symbols represent dilutions enriched with inorganic macronutrients, and open squares represent undiluted water without nutrients (see text for details).

#### a) Estimation of phytoplankton primary production and the impact of microzooplankton grazing

Use natural initial chlorophyll a concentration to estimate phytoplankton biomass ( $B_0$ ) assuming an average C:Chlorophyll a ratio of  $50 \text{ mg C} \cdot (\text{mg Chlorophyll a})^{-1}$ . Use initial phytoplankton biomass ( $B_0$ ) and *in situ* instantaneous growth rate of phytoplankton ( $\mu$ ) to estimate phytoplankton net primary production (PP; **equation 8**, see **Annex**). Then, combine both phytoplankton biomass ( $B_0$ ), *in situ* instantaneous phytoplankton growth rate ( $\mu$ ), and microzooplankton grazing rate ( $g$ ) to estimate the impact of microzooplankton grazing ( $l$ ), as the percentage of daily phytoplankton production grazed by microzooplankton (**equation 9**, see **Annex**).

### 6. Analyzing the results

1. Compare chlorophyll a concentrations in different dilutions at the beginning of the experiment. Do values indicate that experimental dilutions were in fact close to the expected dilutions?
2. Do apparent phytoplankton growth rates in different enriched dilutions statistically differ?
3. Is the relationship between dilution and apparent phytoplankton growth rates in enriched dilutions linear and negative as expected?

4. Do apparent phytoplankton growth rates in undiluted samples with (DIL 1.0+) and without nutrient addition (DIL 1.0) statistically differ?
5. What is the relationship between potential instantaneous growth rate of phytoplankton and in situ instantaneous growth rate of phytoplankton?
6. What is the relationship between in situ instantaneous growth rate of phytoplankton and microzooplankton grazing rate?
7. In case different sites were analysed, are there significant spatial differences in terms of in situ instantaneous growth rate, grazing rate, net phytoplankton primary production or microzooplankton grazing impact?

## 7. Discussion

1. How did nutrient additions affect the apparent growth rate of phytoplankton in the undiluted water sample? Discuss the usefulness of nutrient additions in dilution experiments.
2. In case of incubations under simulated in situ conditions, did water temperature inside the incubation tank attained values significantly different from values usually observed in situ? Discuss strategies to compensate this problem (e.g., application of standard Q10 temperature coefficients values for biological systems, usually between 1.5 and 2.5).
3. Discuss the advantages and disadvantages of using a higher or lower number of dilutions.
4. Positive or nonlinear relationships between dilution factor and phytoplankton apparent growth rates can be obtained in dilution experiments. Discuss the technical and ecological circumstances that can generate these patterns.
5. Discuss the expected results of dilution experiments if applied to eutrophic aquatic systems where feeding rates of microzooplankton are saturated. Discuss data treatment strategies to compensate this problem.
6. Based on phytoplankton primary production and microzooplankton grazing impact values obtained discuss the expected short-term variability in phytoplankton biomass in situ. Integrate information on other relevant phytoplankton loss processes in the aquatic system.
7. During this practical experiment, chlorophyll a concentration was used as a proxy of phytoplankton biomass. However, microscopic analysis can also be used to quantify the abundances of specific groups of phytoplankton and phagotrophic protists in different dilutions at the beginning and end of each experiment. Discuss the advantages of having this type of information on the treatment and interpretation of data using dilution experiments.

## REFERENCES

1. Calbet A. & Landry M. 2004. Phytoplankton growth, microzooplankton grazing, and carbon cycling in marine systems. *Limnology and Oceanography* 49:51-57.
2. Domingues R.B., Barbosa A.B. 2009. Effects of nutrient and light enrichment on phytoplankton growth. *In: L. Chícharo, I. Wagner, M. Lapinska and M Zalewski (eds). Practical Experiments Guide for Ecohydrology, UNESCO-Bresce, UAlg, EcoReach, ERCE a/u UNESCO, PAN, DAE UL.*
3. Holmes R.W. 1970. The Secchi disc in turbid coastal waters. *Limnology and Oceanography* 15:688-694.
4. Landry M. 1993. Estimating rates of growth and grazing mortality of phytoplankton by the dilution method. *In: P.F. Kemp, B.F. Sherr, E.B. Sherr and J.J. Cole. Handbook of Methods in Aquatic Microbial Ecology. Boca Raton, Lewis Publishers. 715-722 pp.*
5. Landry M.R., Hassett R.P. 1982. Estimating the grazing impact of marine microzooplankton. *Marine Biology* 67:283-288.
6. Parsons T.R., Maita Y., Lalli C.M. 1984. *A Manual of Chemical and Biological Methods for Seawater Analysis. Pergamon Press.*
7. Poole H.H., Atkins W.R.G. 1929. Photoelectric measurements of submarine illumination throughout the year. *Journal Marine Biological Association United Kingdom* 16:297-325.
8. Zalewski M. 2000. Ecohydrology-the scientific background to use ecosystem properties as management tools toward sustainability of water resources. *Guest Editorial in Ecological Engineering* 16:1-8.

## ANNEX

### Formulas:

**equation 1**

$$I_m = I_o \cdot (1 - e^{-K_e \cdot Z_m}) \cdot (1 / K_e \cdot Z_m)$$

**equation 2**

$$K_e = 1.7 / Z_s$$

**equation 3**

$$K_e = 1.4 / Z_s$$

**equation 4**

$$r_i (d^{-1}) = (\ln \text{Chl}_{t-i} - \ln \text{Chl}_{0-i}) / \Delta t$$

**equation 5**

$$y = ax + b$$

**equation 6**

$$\Delta r = r_{\text{DIL}1.0+} - r_{\text{DIL}1.0}$$

**equation 7**

$$\mu = \mu_0 - \Delta r$$

**equation 8**

$$PP = (B_o \cdot e^{\mu t}) - B_o$$

**equation 9**

$$I = 100 [(B_0 \cdot e^{\mu t} - B_0) - (B_0 \cdot e^{(\mu - g)t} - B_0)] / (B_0 \cdot e^{\mu t} - B_0)$$

**Legend:**

**B<sub>0</sub>** – initial phytoplankton biomass in undiluted water sample ( $\mu\text{g.C.L}^{-1}$ )

**Chl<sub>0-i</sub>** – chlorophyll *a* concentration in the dilution *i* at the beginning of the experiment ( $\mu\text{g.L}^{-1}$ )

**Chl<sub>t-i</sub>** – chlorophyll *a* concentration in the dilution *i* at the end of the experiment ( $\mu\text{g.L}^{-1}$ )

**g** – microzooplankton grazing rate (units:  $\text{d}^{-1}$ )

**I** – impact of microzooplankton grazing upon phytoplankton production (% of phytoplankton production removed daily)

**I<sub>0</sub>** - average light intensity in the surface ( $\mu\text{E.m}^{-2}.\text{s}^{-1}$ )

**I<sub>m</sub>** - average light intensity in the mixed layer ( $\mu\text{E.m}^{-2}.\text{s}^{-1}$ )

**K<sub>e</sub>** – vertical light extinction coefficient ( $\text{m}^{-1}$ )

**PP** – net phytoplankton production ( $\mu\text{g.C.L}^{-1}.\text{d}^{-1}$ )

**r<sub>i</sub>** - apparent phytoplankton growth rate in dilution *i* ( $\text{d}^{-1}$ )

**r<sub>DIL1.0+</sub>** - apparent phytoplankton growth rate in nutrient enriched undiluted water sample ( $\text{d}^{-1}$ )

**r<sub>DIL1.0</sub>** - apparent phytoplankton growth rate in undiluted water sample without nutrient additions ( $\text{d}^{-1}$ )

**t** – time (d)

**Δt** - duration of incubation (d)

**μ** - *in situ* instantaneous growth rate of phytoplankton ( $\text{d}^{-1}$ )

**μ<sub>0</sub>** – potential instantaneous growth rate of phytoplankton ( $\text{d}^{-1}$ )

**Z<sub>m</sub>** – Secchi disk depth (m)

**Z<sub>s</sub>** - mixed layer depth (m)

## 8. ANALYSIS OF DYNAMICS AND SUCCESSION OF FILTERING ZOOPLANKTON IN DIFFERENT HYDROLOGICAL CONDITIONS.

### Chapter Objectives

To demonstrate how hydrological processes may regulate biota:

- Comparative analysis of growth and reproduction of filtering zooplankton in the stable and unstable hydrological conditions;
- Examination of the food quality effect on filtering zooplankton by offering them diet characteristic for stable hydrological conditions (algae) or for flooding conditions (suspended mixture of mineral and organic matter).
- Comparison of magnitude of nutrient recycling by zooplankton depending on food composition and hydrological conditions.

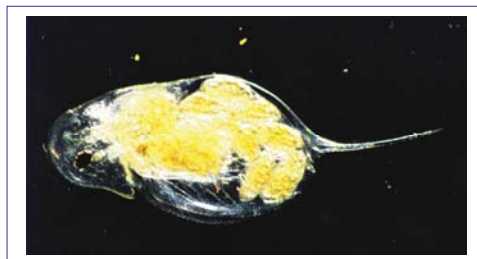

*Daphnia sp.* (photo A. Wojtal-Frankiewicz)

**EH principle: 1 – identification and quantification of processes, 3 – dual regulation**

### INTRODUCTION

Cladocerans are the important component of most lake zooplankton communities, due to their capability to filter all particles within a given size range, including bacteria, protozoa, detritus and algae (Greenwood *et al.* 1999). They affect the composition and abundance of phytoplankton species, both by direct grazing and by nutrient regeneration (Carney, Elser 1990), especially during stable hydrological conditions. **According to EH concept hydrological instability (flush floods, long and deep droughts, etc.) may decrease importance of biotic interactions (Zalewski 2000). Proposed experiment may contribute to explanation to what extent hydrological processes can change or reverse a zooplankton succession pattern and, in consequence, structure of aquatic food chain.** Tasks to explain in practical terms:

- comparison of filtering cladocerans growth and reproduction in good food conditions (edible algae) but different hydrological conditions (stable and with simulated flow);
- how high sediment turbidity and diet shift (from algae to detritus) influence cladocerans growth rate and their fecundity parameters;
- estimate cladocerans excretion (nutrient regeneration) in all experiment treatments.

### ELABORATING THE EXPERIMENT

#### 1. General description

**Methods for evaluation of daphnids grazing activity:**

**a) The filtering rate** [mL<sup>-1</sup> h<sup>-1</sup>] in treatment with algae will be calculated according to formula:

$$Fr = V [(ln Chla0 - ln Chla1) - (ln Chla'0 - ln Chla'1)] / t$$

where: **V** – experimental volume [mL]

**Chla0, Chla1** – the initial and final concentration of chlorophyll a [mg L<sup>-1</sup>], respectively

**Chla'0, Chla'1** - the initial and final concentration of chlorophyll a in control [mg L<sup>-1</sup>]

**t** – time of the experiment in hours

Chlorophyll a will be analyzed on fluorometer or using the ethanol extraction method.

**b) Total suspended matter content** will be determined by filtering water through 0.45 mm filters of known weight and then drying at 105°C (24h). Mineral suspended matter content will be determined by next burning of the filters at a temperature of 500°C (24h). Organic suspended matter content will be calculated as the

difference between total and organic suspended matter contents.

#### Methods for evaluation of reproductive parameters:

a) **Mean clutch size (CS)** will be calculated:

$$CS = E / N_a$$

where:

**E** - egg number

**N<sub>a</sub>** - number of adult daphnids

b) **Mean brood size (BS)** will be calculated:

$$BS = E / N_c$$

where:

**N<sub>c</sub>** - number of egg carrying daphnids

c) **Proportion of egg carrying adults (Ad)** will be evaluated:

$$Ad = N_c / N_a$$

d) **The rate of *Daphnia sp.* population abundance change (r)** will be calculated with use of the equation:

$$r = (\ln N_t - \ln N_0) / Dt$$

where:

**N<sub>0</sub>, N<sub>t</sub>** - initial and final population abundance, respectively

**t** - time between the two observations (in hours – in short-time exp. or in days – in long-time exp.).

#### Methods for evaluation of nutrient recycling:

a) **Water for chemical analyses** will be filtered through Whatman GF/F filters and analyzed for phosphate phosphorus (P-P<sub>04</sub>) and ammonium nitrogen (N-NH<sub>4</sub>) concentration according to colorimetric method (Greenberg *et al.* 1992), nitrite and nitrate nitrogen (N-NO<sub>2/3</sub>) according to Golterman *et al.* (1988). Samples of non filtered water for TP analysis will be digested e.g. with MERCK MW 500 Microwave Digestion System and determined by the ascorbic acid method (Greenberg *et al.* 1992). Absorbance will be measured with a spectrophotometer.

## 2. Experimental design

The experiment will include two treatments : **A (algae)** and **SM (suspended matter)**. The experiment will be conducted in 2-liter glass

beakers with 5 replicates for each treatment (**A & SM**). All beakers will be filled with filtered water from natural ecosystem. You will need to use *Daphnia* individuals 0.8-1.2 mm long (e.g. *D. hyaline*, *D. cucullata*, or *D. longispina* etc.). You can use monospecific algae cultures or organisms from natural ecosystem (than you have to do initial analysis of fitoplankton community). The experiment will be conducted with a light/dark regime of 12:12 h at 21 °C.

#### Treatment A (algae) will include:

- control** – 2 L water + initial concentration of edible algae (with 5 replicates);
- treatment A stable** - 2 L water + initial concentration of edible algae + 50 individual of *Daphnia sp.* (with 5 replicates);
- treatment A unstable** - 2 L water + initial concentration of edible algae + 50 individual of *Daphnia sp.* (with 5 replicates). The beakers will be placed on a magnetic stirrer (80 ± 20 rpm) over day simulated high inflow and unstable hydrological conditions.

#### Treatment SM (suspended matter) will include:

- control** - 2 L water + 65 mg DW L<sup>-1</sup> bottom sediment (10 nephelometric turbidity units – NTU) – with 5 replicates;
- treatment SM stable** - 2 L water + 65 mg DW L<sup>-1</sup> bottom sediment + 50 individual of *Daphnia sp.* (with 5 replicates);
- treatment SM unstable** - 2 L water + 65 mg DW L<sup>-1</sup> bottom sediment + 50 individual of *Daphnia sp.* (with 5 replicates). The beakers will be placed on a magnetic stirrer (80 ± 20 rpm) over day.

You will be able to perform the experiment with different variant of time:

**1. Short-time experiment (24-48 h)**, where you will evaluate:

- filtering rate of *Daphnia sp.* (initial and final concentration of chlorophyll a);
- grazing *Daphnia sp.* on suspended matter (initial and final values for organic and inorganic matter);
- chemical analyses of water for examine daphnids excretion (initial and final values);
- growth rate of daphnids (initial and final values).

**2. Long-time experiment (7-10 days)**, where you will evaluate:

- filtering rate of *Daphnia sp.* (concentration of chlorophyll a measured every 2 days);

- grazing *Daphnia sp.* on suspended matter (initial and final values for organic and inorganic matter);
- chemical analyses of water for examine daphnids excretion (concentration of P-P04; N-NH<sub>4</sub>; N-NO<sub>2/3</sub>; TP should be measured three times);
- growth rate of daphnids (measured every 2 days);
- reproductive parameters (initial and final values of clutch size, brood size and proportion of egg carrying adults).

### 3. Materials and equipment

#### a) Field work

You will need materials and equipment to collect water and zooplankton from water ecosystem:

- Baskets and containers for water collection and transport to the laboratory;
- Plankton net with a 50 mm mesh size and bottles (2-4-liter) for plankton collection and transport;
- Clothing: water proof boots to walk on the margins, water proof jacket.

#### b) Laboratory experiments

Basically you will need:

- 30 glass beakers;
- 80-liter aquarium for the water brought from the natural zooplankton habitat;
- 10 magnetic stirrers;
- pump to filter the water for the chemical analysis;
- whatman GF/F filters for chemical analysis of water;
- microwave Digestion System for samples digestion;
- photometer or reagents and spectrophotometer for nutrients determination;
- fluorometer or reagents and spectrophotometer for chlorophyll determination;
- sediment sampler and plastic containers for transporting and storing sediments;
- stove for sediment samples drying;
- 4% Lugol solution for zooplankton samples preservation;
- microscope for analysing reproductive parameters;
- pipettes.

#### c) Data analysis

- computer;
- data sheet organizer;
- basic graphic software.

### 4. Data organizing and analysis

#### Organizing the data

You can use the proposal of data sheet (Table 1 see Annex).

#### Basic statistical analysis

What we can do with the data?

1. Analysis variability within replicates.
2. Compare results calculated with different hydrological condition and food base.

#### What statistical tests should be used?

It is suggested Kruskal-Wallis analysis.

#### Making graphs

Testing graphical representation of the results.

### 5. Analysing the results

You should answer on several questions analysing the results:

1. What is the effect on *Daphnia* growth rate and reproductive parameters grazing of resuspended sediment? Compare results from Treatment A.
2. Compare influence of light conditions on *Daphnia* dynamics (in light intensity – treatment A, and in high turbidity treatment SM).
3. Is hydrology or diet more responsible for *Daphnia* life history?
4. May the hydrology conditions change trophic interactions? To what extent?
5. On the base of achieved results try to estimate the hierarchy of biotic and abiotic factors influencing biota structure interactions in water ecosystems.
6. If you have to do this experiment again, what would you change? Why?

### REFERENCES

1. Carney H.J., Elser J.J. 1990. Strength of zooplankton-phytoplankton coupling in relation to lake trophic state. *In*: M. M. Tizler, C. Serruya (eds.). Large Lakes: Ecological Structures and Funktions. Springer-Verlag, New York. 615-631 pp.
2. Greenberg A.E., Clesceri L.S., Eaton A.D. 1992. Standard Methods for the Examination of Water and Wastewater. American Public Health Association, Washington.
3. Greenwood T.L., Green J.D., Hicks B.J., Chapman A. 1999. Seasonal abundance of small cladocerans in lake Mangakaware,



## 9. MAY THE PRESENCE OF BIVALVES AFFECT THE DEPOSITION OF SPM AND ASSOCIATED POLLUTANTS, *i.e.* SPILLED HYDROCARBONS?

### Chapter Objectives

To demonstrate how the presence of filter feeding activity of bivalves could modify deposition rate of suspended particulate matter in a water body.



*Dreissena polymorpha* (photo A. Wojtal-Frankiewicz)

**EH principle: 2 – enhancement of ecosystem absorbing capacity**

### INTRODUCTION

Bivalves filter phytoplankton, bacteria and suspended particulate matter (SPM) from the water column. Depending on water characteristics *Limnoperna fortunei* could remove SPM from water column and accelerate its bio-deposition as faeces. Thus, depending on SPM concentration and bivalve density this process could significantly increase deposition rates. As many pollutants with low water solubility's are adsorbed to SPM (*i.e.* hydrocarbons, PCBs), the enhanced bio-deposition could affect their dynamic and fate in aquatic ecosystems.

Some burrowing bivalves are also deposit feeders (*i.e.* *Corbicula sp.*) and could modify water column as well as sediments processes (Colombo et al. 2006, 2007).

### ELABORATING THE EXPERIMENTS

#### 1. General description

The natural deposition rates of SPM will be compared. The effect of bivalve filtration activity will be studied by placing individuals in aquaria with four different SPM concentrations.

The filtration rate will be assessed with different SPM concentrations. Modification in relation C:N in SPM will be studied at the beginning and end of experiment.

Faeces formed during the assay will be collected and analyzed at the end of the assay.

In a second stage, a well known mixture of hydrocarbon will be added to triplicates of one group and control, in order to study the effect of bio-deposition on the elimination of different compounds from water column, bioaccumulation

and incorporation to faeces as well as their effect on C:N balance.

#### 2. Experimental design

##### Biodeposition rates

The experiment design considers 4 concentration of SPM (50, 100, 200 and 400 mg/l) (see **Figure 1**). For each of these experimental conditions triplicates were considered. Two controls were considered for each experimental group; one without animals and other with closed empty valvae.

#### 3. Material and equipment

##### Sampling material

- containers for water collection and transport;
- sharp instruments to cut substrate and viso of mussels;
- small shovel to get *Corbicula*;
- plastic bags for transportation of animals to the laboratory in a refrigerated container;
- containers to place collected bivalves and maintain them in experimental conditions;
- clothing: water proof boots to walk on margins or waders and water proof jacket.

##### Animal and water collection: handling

All individuals will be depurated over night in artificial fresh water.

##### Two experimental handling for animals were proposed:

**A.** *Limnoperna fortunei* will be collected from the environment fixed to their substrate and transported to laboratory.

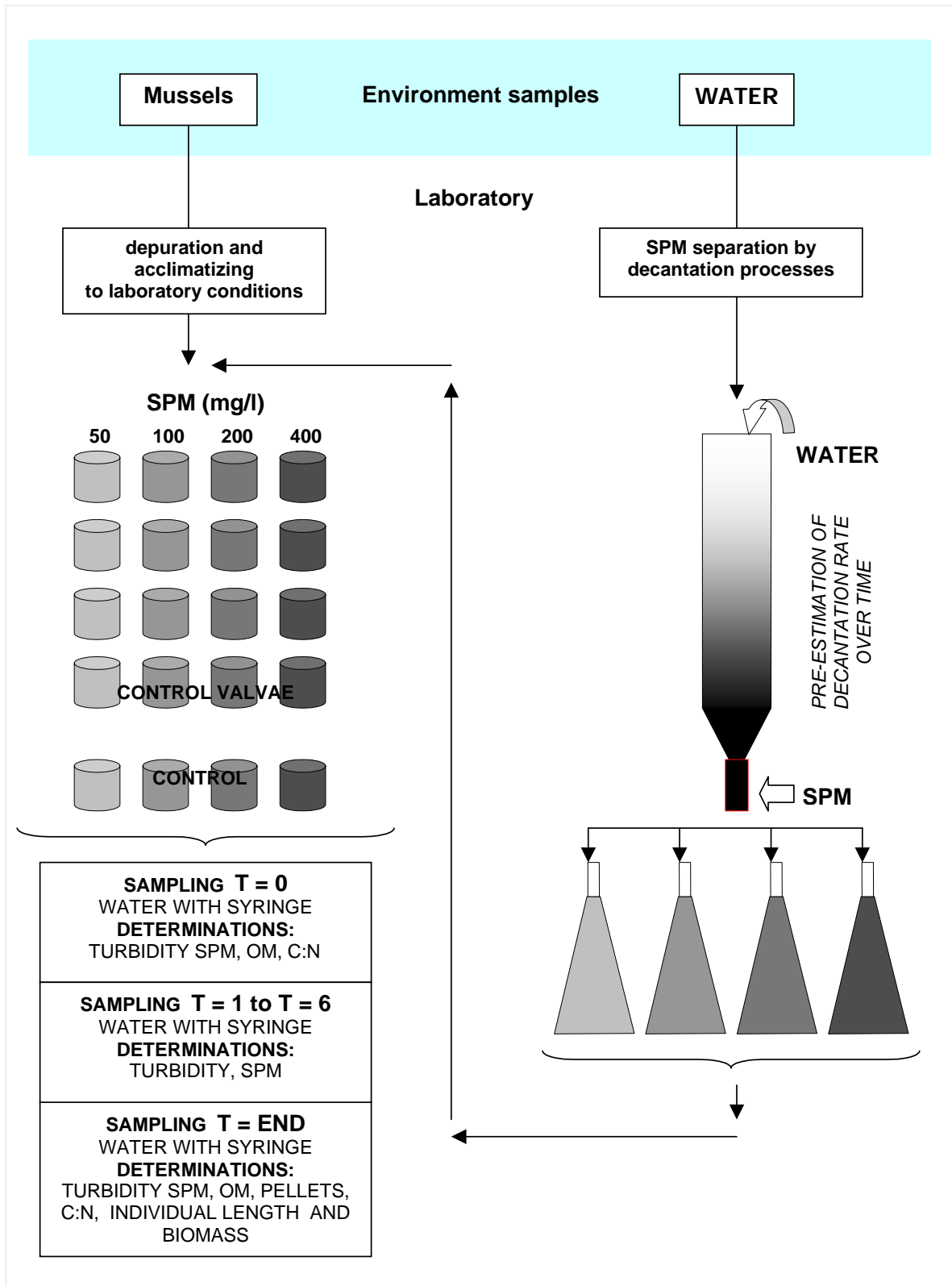

Figure 1. The design of the experiment.

**B. *Limnoperna fortunei*** will be collected from the environment cutting the viso and after their transportation to the laboratory, they will be disposed on glass with irregular surface to allow them to re-synthesize their viso. All animals attached correctly and showing filtration activity will be considered suitable for experiment, on the contrary will be removed.

Water samples will be collected and transported to the laboratory in containers at 4 °C and put in decanters in order to obtain SPM to be physico-chemically characterized and to prepare working suspension, starting from semi hard fresh water (EPA,.....).

#### **Total Water, SPM and faeces analysis**

Pre-weighted cup or filters (GF 0,7 µm, 13 mm diameter) will be used to determine SPM by gravimetry (100°C 24 hs), a rough determination of organic matter will be estimated by sample reduction to ashes (600°C, x hs STANDARD METHODS).

Total hydrocarbon content will be quantified by IR.

Composition of mixture will be determined by extraction with solvents, purification and identification and quantification by GC-MS. Finally C:N relationship will be determined by an elemental analyzer.

#### **Laboratory experiments**

A wet laboratory will be needed, preferably with photoperiod and temperature controls.

- 20 glass containers for controls and treated groups;
- decantation devices for separation of SPM;
- containers with agitation for SPM suspension preparation;
- turbidimeter, syringes, filter holders, pre-weighed filters and cups, to follow deposition evolution;
- caliper to determine size of animals;
- oven and muffle for determination of SPM and determination of dry tissue weigh and ash free dry tissue weigh;
- Elemental Analyzer;
- IR;
- GC-MS;
- ultra sonic bath for extraction;
- balance;
- magnetic stirrer to prepared hydrocarbon mix.

#### **Data Analysis**

- computers;

- data sheet organizer;
- basic graphic and statistic software.

#### **4. Experiment description**

**STAGE 1.** After depuration of animals, they will be randomly grouped and left in air exposure for 1 hour. All experimental aquaria (2,5 l) will be filled with 2 l of SPM suspension and stirred; one sample of water will be taken before adding the animals (five with standardized size) and time zero will be registered for each container when animals begin to show filter activity (this time must be recorded).

These water samples will be used for chemical analysis. Samples of water must be taken at 0, 0.5, 1, 3, 6, 12 and 24 hours, and determination of deposition rate by filtering and turbidity lectures must be done.

The experiment will be continued until no turbidity values in control becomes constant.

At the end of experiments, animals will be removed and measured, then opened by cutting abductor muscles and weighed. Soft parts will be removed and weighed to determinate fresh biomass, then dried weigh and ash free weigh will be determined in order to estimate deposition rate related to animal biomass.

A comparison of effectiveness of biodeposition in different concentrations of SPM has to be performed.

Pellets and SPM remaining in aquaria will be used to determine C:N relationships.

**STAGE 2.** A preparation of SPM enriched with hydrocarbons in a concentration similar to that occurred during an oil spill, will be suspended in artificial water by stirring.

The concentration to be used will be estimated from a NOEC or LD10 96 hours assay performed previously or using NOEC estimated for *Dreissena sp.*

The experimental procedure will be similar to that described above.

At the beginning and the end of experiment hydrocarbons determination will be included and animal bioaccumulation from SPM will be analyzed too.

#### **REFERENCES**

1. Colombo, J.C., N. Cappelletti, J. Lasci, M.C. Migoya, E. Speranza & C.N. Skorupka. 2006. Sources, vertical fluxes and equivalent toxicity of aromatic hydrocarbons in coastal sediments of the Río de la Plata Estuary, Argentina.

Environmental Science and Technology, 40: 734-740.

2. Colombo, J.C., N. Cappelletti, E. Speranza, M.C. Migoya, J. Laschi & C.N. Skorupka 2007. Vertical fluxes and organic composition of settling material from the sewage impacted Buenos Aires coastal area, Argentina. - Organic Geochemistry, 38: 1941-1952.

#### ANNEX

#### CHRONOGRAM STAGE 1

SAMPLING TIME (HOURS)	DETERMINATIONS
0,5	TURBIDITY SPM, OM, C:N
1	TURBIDITY AND SPM
3	TURBIDITY AND SPM
6	TURBIDITY AND SPM
12	TURBIDITY AND SPM
24	TURBIDITY SPM, OM, PELLETS, C:N AND INDIVIDUAL LENGTH AND BIOMASS

#### CHRONOGRAM STAGE 2

SAMPLING TIME (HOURS)	DETERMINATIONS
0,5	TURBIDITY SPM, OM, C:N, TOTAL HYDROCARBON AND CHARACTERIZATION OF MIXTURE IN SPM
1	TURBIDITY AND SPM
3	TURBIDITY AND SPM
6	TURBIDITY AND SPM
12	TURBIDITY AND SPM
24	TURBIDITY SPM, OM, PELLETS, C:N AND INDIVIDUAL LENGTH AND BIOMASS TOTAL HYDROCARBON AND CHARACTERIZATION OF MIXTURE IN SPM, PELLETS AND ANIMALS

## 10. MAY BIVALVES BE USED TO CONTROL TOXIC ALGAE BLOOMS?

### Chapter Objectives

To demonstrate how to use bivalve filter feeding activity to control toxic algal blooms.



*Scrobicularia plana* (photo L. Chicharo)

**EH principle: 2 – enhancement of ecosystem absorbing capacity**

### INTRODUCTION

**Theoretical fundamentation of the experiment in the light of EH approach as solution for water quality and quantity related issues :**

- To explain how the proposed experiment may contribute, in practical terms, for solving water related problems.
- To use of bivalve filter feeding activity to control toxic algal blooms.

### EXPERIMENT DESCRIPTION

#### 1. General description

The physiological rates – filtration, excretion and respiration rates of two bivalve species will be compared, in three different salinities. Bivalves will be placed, individually, in aquaria. Water from local of origin of the bivalves will be used in open circulation system. The filtration rate will be assessed by the reduction in phytoplankton biomass, estimated from the concentrations of chlorophyll *a*. Chlorophyll will be measured in vivo with a fluorometer or will be processed for spectrophotometric analysis. The excretion rate will be determined based on the analysis of the ammonia concentration, over time, in other aquaria. Ammonia concentration will be measured with a photometer. For evaluation of the respiration rate bivalves will be placed individually in closed containers, filled with water and with one opening on the top. The decrease in oxygen concentration in the water will be measured over time (for more details see Chicharo et al 2009).



#### 2. Experimental design

The experiment design considers 3 salinity values (0.2, 4.2 and 10). For each of these salinity values triplicates of each physiological rate (filtration, respiration and excretion) were considered. A control was considered for each situation.

#### 3. Materials and equipment

##### a) Field experiments

You will need materials and equipment to collect water, bivalves and to measure environmental water parameters:

- baskets and containers for water collection and transport to the lab (Consider that in warmer and hot climates, the dilution of atmospheric oxygen into the water decreases and you may need an oxygen pump);
- small hand-dredge for bivalve sampling in ponds or dredge to be towed from a boat;

- containers to place the bivalves collected – at least 50 bivalves (if you will use the experimental design above!);
- probe to measure the water environmental parameters;
- clothing: water proof boots to walk on the margins, water proof jacket.

#### b) Laboratory experiments

You will need to use a wet lab, preferably with aquaria systems, oxygen pumps and water circulation. If not available you can just use a desk to prepare the experiment.

Basically you will need:

- 45 glass containers for the bivalves;
- larger aquarium for the water you brought from the natural bivalves habitat;
- pump to bring the water to the containers where the filtration experiment occurs;
- respirometers (hermetically closed boxes) for respiration analysis;
- fluorometer or spectrophotometer for chlorophyll determination;
- photometer for nutrients determination;
- kits for nutrients determination (consider a preliminary analysis to choose the adequate range);
- GF/C filters for chlorophyll;
- calliper;
- oven and muffle for determination of bivalves AFDW (ash free dry weight).

#### c) Data analysis

- computer;
- data sheet organizer;
- basic graphic software.

#### d) Safety information

*Check the weather forecast before going to the field. Use appropriate clothing. Do not walk into deeper water or enter a boat wearing your water proof boots. Beware of touching electric devices with your hands wet. Be very careful when using all electric equipments.*

### 4. Experiment description

Filtration of the water by less than 30 µm to eliminate other organisms (zooplankton) that can feed on the phytoplankton (and bias the filtration rate) and consume oxygen (and bias the respiration rate results), etc.

### 5. Organizing the data

#### Organizing the data

Proposing a data sheet

Basic statistical analysis

Size matters

Remove the size effect from your data (ex. for the bivalve experiment)

What we can do with the data?

Analysis variability within replicates.

Compare rates calculated with different salinities.

#### What statistical tests use?

T- student.

#### Making graphs

Testing graphical representation of the results.

### 6. Analysing the results

1. What salinity value promotes the best physiological response?
2. There were significant differences in response from different individuals?
3. Which physiological rate seemed to be more sensitive to salinity changes?
4. How did the rates varied with the size of the bivalves?

### 7. Discussion

1. What physiological rate you will choose to detect salinity changes in the analysed environment?
2. If the salinity values in the analysed area varied what you think will be the consequence to the studied bivalve species in terms of its distribution and abundance?
3. If you have to do this experiment again, what would you change? Why?

### REFERENCES

1. Bayne, B.L., Hawkins, A.J.S., Navarro, E., 1987. Feeding and digestion by the mussel *Mytilus edulis* L. (Bivalvia, Mollusca) in mixtures of silt and algal cells at low concentrations, *J. Exp. Mar. Biol. Ecol* 3: 1-22.
2. Chícharo L., Ben-Hamadou R., Amaral A., Range R., Mateus C., Piló D., Marques R., Chícharo M.A. 2009 Application and demonstration of the Ecohydrology approach for the sustainable functioning of the Guadiana estuary (South Portugal). *Ecohydrology and Hydrobiology (in press)*.
3. Jorgensen, C.B., 1943. On the water transport through the gills of bivalves. *Acta Physiol. Scand.* 5, pp. 297–304

## ANNEX

Formulae you will need:

Ingestion and filtration rates, expressed as volume of water cleared of suspended chlorophyll particles per unit time, were determined using a closed system approach, using a 250 ml flask containing filtered seawater with a known concentration of micro algae. Measurements were taken every 30 min. for 1 hour and half using a 10 -AU fluorometer (chlorophyll in vivo). Ingestion rates (IR) were calculated from these data, following Jorgensen (1943).

The excretion rate of ammonium was determined by placing bivalves in closed chambers filled with 250 ml air - saturated water previously filtered through 0,2 µm Millipore membranes. An additional flask without animals was set-up to control for other sources of variation in the concentration of ammonium. After 150 min., 10 ml samples of water were taken from each experimental chamber to be analysed. Excretion rates were calculated as:

$$e_{NH_4} = \left( \frac{V}{AFDW \cdot t} \right) \left( (Cf_e - Ci_e) - (Cf_c - Ci_c) \right)$$

Where V= volume of the flask, AFDW = ash free dry weight of all the animals in the flask, t = measured period, Cie and Cfe = initial and final ammonium concentrations in the experimental flasks, and Cic and Cfc = initial and final ammonium concentrations in the control.

These rates were corrected to a standard-sized individual to preclude variability in physiological rates caused by differences in size. To this end, once the physiological measurements were completed, the shell length of each individual was recorded to the nearest 0.1 mm with vernier callipers and the soft tissues excised from the shell, dried at 110°C for 12h and weighted. Physiological rates were then standardized to 1g dry weight individual, following the formula of Bayne et al. (1987).



## 11. How do different growth forms of aquatic plants influence the oxygen concentration within a water body?

### Chapter Objectives

To demonstrate the aquatic macrophyte growth-form effects on oxygen and shading conditions in a waterbody.



Macrophytes (photo ERCE)

### EH principle: 1 – quantification of processes

#### INTRODUCTION

The experiment gives a basic insight to the role of aquatic macrophytes in water bodies related to their application in **EH governed management of algal “blooms”** (Zalewski 2000). Macrophytes are a source of autochthonous carbon and oxygen (Janauer 2001, Wetzel 2001) and compete with phytoplankton for light and nutrients. Aquatic heterotrophs (animals, fungi, most bacteria) crucially depend on oxygen for respiration (Janauer, Dokulil 2006). The diffusion of oxygen from the atmosphere to the water body is of importance, too, but plant growth in the water, and on the water surface, influences oxygen availability to a great extent. The main question here is **which growth form of macrophytes is the overall best following EH principles of applying ecosystem properties for mitigating man-induced mass development of phytoplankton algae, when seeing macrophytes as ‘biological drivers’ in ecosystem functioning** (Zalewski *et al.* 2008).

#### ELABORATING THE EXPERIMENT

##### 1. General description

The oxygen production of submersed and of free floating aquatic plants is compared in a simple experiment.

##### 2. Experimental design

It is recommended to run this experiment as a qualitative presentation that needs no replicates. Alternatively, the quantification of the oxygen production can be done via the assessment of the photosynthetic plant mass within the water of the experimental glass beaker, time of exposure

to light, start and final oxygen content. Attention: some roots may emit small amounts of oxygen.

##### 3. Material and equipment

Two high and slender glass beakers (*alternative*: clear plastic containers). Aluminium foil large enough to completely cover the vessels. Two different growth forms of aquatic plants: a submersed species (e.g. *Hydrilla*, *Egeria*, Hornwort / *Ceratophyllum sp.*) and a free-floating species (e.g. Water Lettuce / *Pistia sp.*, Water Hyacinth / *Eichhornia sp.*). For oxygen determination use an oxygen electrode or a chemical oxygen determination kit (e.g. Merck oxygen test Nr.1.11107.0001).

##### 4. Experiment description

Best results will be achieved with water containing very little or no oxygen. This can be produced in two ways:

**a) Biological approach:** fill the two beakers with tap water and plant material (Beaker 1: submersed plant, Beaker 2: free-floating plant). Cover the whole surface of the beakers with aluminium foil to keep plants in total darkness (period: 24 to 36 hours) (**Figure 1**).



**Figure 1.** Beaker, wrapped up in aluminium foil to keep plants in darkness.

All or at least most of the original oxygen in the water should be used up by respiration of the plant tissue. After the darkness period: measure oxygen content.

**b) Physical approach (alternative) :** Boil a sufficient amount of water to fill the two beakers for at least 15 minutes. Cool to c. 15 to 20 °C. Fill the beakers with the plant material. Then fill the cooled water with as little as possible turbulence to the beakers (e.g. using a small-diameter rubber hose) to reduce oxygen replenishment. Cover the beakers with aluminum foil. After the darkness period: measure oxygen content.

Unwrap beakers and expose to direct sunlight (**Figure 2**).



**Figure 2.** (left) Hornwort (*Ceratophyllum demersum*) and (right) Water Lettuce (*Pistia stratiotes*).

After 2 to 5 hours measure oxygen content again.

*Alternative:* follow the development of the oxygen concentration during the period of light exposure. Avoid much stirring of the water as additional oxygen may be introduced from the atmosphere.

### 5. Organizing the data

Produce a table with the results of your measurements:

Oxygen concentration	Time	Hydrilla (submerged)	Pistia (free floating)	Comments
O <sub>2</sub> Start (mg/l)				
O <sub>2</sub> (mg/l)				
O <sub>2</sub> (mg/l)				
... ..				
O <sub>2</sub> Final (mg/l)				

If you have done a time series a diagram will show the increase in oxygen concentration.

### 6. Analysing the results

You can calculate the oxygen development relating to the number of individuals of your plants or their stem length (for submerged species) or number of leaves (free-floating species). *Attention:* this will only approximate the real influence of the plants in their natural environment.

### 7. Discussion

1. What has happened?
2. How does the growth form influence the oxygen content of the water?
3. Discuss the situation in natural water bodies with either a dominance of submerged or of free-floating plants (Pieterse, Murphy 1990, Caffrey *et al.* 2006).
4. How may other life forms react to such conditions?

When applying EH strategies, i.e. ecosystem services of aquatic vegetation, for fighting algal blooms (= mass development of plankton algae):

1. Which growth form will be the most effective with respect to light requirement of the phytoplankton algae?
2. Which growth form will compete better with respect to nutrients and occupation of the spatial niche, and with respect to additional benefits for the aquatic biocenosis?

### REFERENCES

1. Caffrey J.M., Dutarte A., Haury J., Murphy K.J., P.M. Wade. 2006. Macrophytes in Aquatic Ecosystems: From Biology to Management. Springer, Dordrecht. 263 pp.
2. Janauer G.A. 2001. Makrophyten. *In:* M. Dokulil, A. Hamm, J.G. Kohl (eds.) Ökologie und Schutz von Seen. Facultas, Vienna. 121-132 pp.
3. Janauer G.A., Dokulil M. 2006. Macrophytes and algae in running waters. *In:* G. Ziglio, M. Siligardi, G. Flaim (eds.) Biological monitoring of rivers. Applications and perspectives. J. Wiley & Sons Ltd., Chichester. 89-110 pp.
4. Pieterse A.H., Murphy K.J. 1990. Aquatic weeds. The ecology and management of nuisance aquatic vegetation. Oxford University Press Inc., New York. 593 pp.

5. Symoens J.J.(ed.). 1988. Vegetation of inland waters 15/1. *In*: H. Lieth (ed.) Handbook of vegetation science. Kluwer Academic Publishers, Dordrecht. 385 pp.
6. Wetzel R.G. (ed.). 2001. Limnology. Lake and River Ecosystems (third edition). Academic Press, San Diego. 1006 pp.
7. Zalewski M. 2000. Ecohydrology - the scientific background to use ecosystem properties as management tools toward sustainability of water resources. Guest Editorial in Ecological Engineering 16:1-8.
8. Zalewski M., Harper D., Demars B., Jolankai G., Crosa G., Janauer G., Pacini N. 2008. Linking biological and physical processes at the river basin scale: the origins, scientific background and scope of Ecohydrology. *In*: Harper, D., Zalewski, M., Pacini, N. Ecohydrology: Processes, Models and Case Studies. An approach to the sustainable management of water resources. CABI, Wallingford. 1-17 pp.



## 12. USE OF SALTMARSH PLANTS TO REMOVE CADMIUM FROM ESTUARINE SEDIMENT.

### Chapter Objectives

To demonstrate how to use saltmarsh plants to remove cadmium from estuarine sediment.



*Guadiana estuary (photo Luis Chicharo)*

**EH principle: 2 – enhancement of ecosystem absorbing capacity**

### INTRODUCTION

Several contaminants including heavy metals can be introduced into the aquatic environment and accumulated in sediment by different pathways, including from human activities along coastlines and upriver. Plants can take up chemical species from the environment and reduce contamination. (Zalewski 2000)

### ELABORATING THE EXPERIMENT

#### 1. General description

##### Materials and reagents

To prevent contamination all sampling and labware materials must be soaked in 20% (v/v) HNO<sub>3</sub> solution for at least 24 h rinsed several times with bidionized water and dried. All reagents used must be pro analysis grade or equivalent. Standard solutions for Cd analysis must be prepared daily from the stock ones, in polyethylene tubes, with 0,1 % HNO<sub>3</sub> solution.

##### Sample collection

Must be selected a plant and two small estuarine sites, one colonized with that vegetal specie and another without plants. On the first site, the plants and the rhizosediment (sediment in contact with the plant roots and rhizomes) must be collected, corresponding to the roots depth. Simultaneously sediment without plant must be collected to the same depth. Each sample must be put into a plastic bag and immediately carried to the laboratory.

##### Sample treatment

On arrival at the lab, plant roots and rhizomes must be removed, rinsed with deionised water, and put to dry into an oven at 40 °C, up to

constant weight. Rhizosediment and sediment, drained for porewater removal, must be dried as the plants, up to constant weight. Large stones and dead roots must be removed from sediments.

For metal content determinations, three independent aliquots of vegetal tissues, sediments and rhizosediments (c.a. 0,30 g) must be digested in closed PTFE vessels at high-pressure, with 6 ml of HNO<sub>3</sub> (65%) + 1 ml of HClO<sub>4</sub> (65%), and only for plant tissues 1 mL of H<sub>2</sub>O<sub>2</sub> (30%), using a microwave system.

Blank solutions must be prepared for each type of sample, following the respective sample treatment.

To check the accuracy of the analytical procedures used for plants and sediments, reference materials, certified for the extractable metal content, must be analysed following the same sample treatment.

##### Cadmium content determination

Total metal content in the different samples will be determined by atomic absorption spectrometry, with electrothermal atomisation provided with appropriated correction. Aqueous matched standards must be used for external calibrations. The results must be expressed in mg/kg of dried mater.

#### 2. Analysis and discussion

Must be prepared a graphical analysis of the results for the different samples, for instance, in case of sediment without plants (see **Figure 1**):

Following questions should be asked:

1. Were there significant differences in sediment and rhizosediment?
2. Were there significant differences in plant (roots and rhizomes) and rhizosediment?

3. Can this vegetal species remove cadmium from estuarine sediment?

**Figure 1.** *The cadmium concentration in sediment profile.*

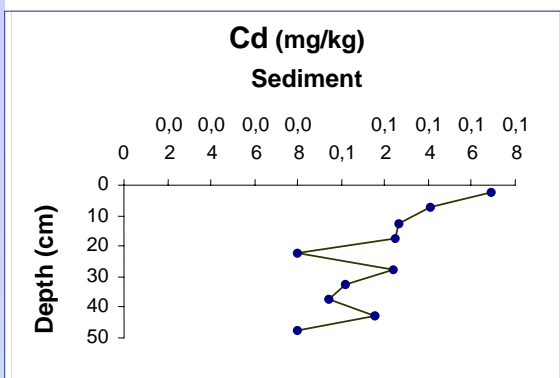

**LITERATURE**

1. Zalewski M. 2000. Ecohydrology - the scientific background to use ecosystem properties as management tools toward sustainability of water resources. Guest Editorial in Ecological Engineering 16:1-8.



**Figure 2-** Several saltmarsh plants (photo Luis Chícharo)

### 13. MODELLING ESTUARINE ECOLOGICAL RESPONSE TO DIVERSE HYDROLOGICAL PATTERNS. BOTTOM-UP CONTROL.

#### Chapter Objectives

Model the bottom-up control of algal blooms in lower estuary as a function of flow regimes.



Alqueva dam, Portugal (photo wikipedia.org)

#### EH principle: 3 – dual regulation

#### INTRODUCTION

In the light of EH approach as solution for water quality and quantity related issues, hydrological regimes in streams, river and estuary could drive phytoplankton communities shift and limitation in terms of abundances.

In fact, planktonic assemblages are highly sensitive to nutrient inputs from dam releases and other point or non-point sources (Chícharo *et al.* 2006). N:P:Si ratios are the structuring feature of phytoplanktonic communities succession since diatoms, contrasting with cyanobacterial or dinoflagellates species, are limited by the 3 nutrients availability (N, P and Si) (Carlsson, Granéli 1999). Decreases in the availability of silica relative to N and P may result in a shift in the phytoplanktonic community from a dominance of diatoms to other phytoplanktonic forms as cyanobacteria (Rocha *et al.* 2002).

**Models appear as a suitable tool to simulate the ecosystem dynamics as a result of ecological restoration or natural variability. In our case, freshwater “pulses” can be managed by operating the freshwater release from hydrotechnical structures (i.e. dams) to avoid cyanobacteria blooms. The understanding of relationships between the periodicity and magnitude of inflow pulse events and the estuarine ecosystem structure and healthy functioning is a crucial step towards the development of this ecohydrological modelling tools (Zalewski 2000, Chícharo *et al.* 2006).**

#### ELABORATING THE EXPERIMENT

##### 1. General description

An ecohydrological model was developed for the Guadiana Estuary (South Portugal, Wolanski *et al.* 2006) and additional sub-models were added

(Chícharo *et al.* 2006, Chícharo *et al.* 2008). These submodels will be studied and used in this chapter to simulate river inflow regimes as precondition to phytoplankton communities arrangement.

Models are written in Matlab language but graphical user interfaces (GUI) are available for novice users for an easier model parametrisation.

Parameters such as dam release frequency and amplitude or simulation extent are introduced by the user. Multiple graphical model outputs are visualized in a multiple-plot for comparison of different settings.

##### 2. Experimental design

Model conceptual scheme is presented in **Figure 1**.

The model consists of three nutrient compartments (Nitrogen “N”, Phosphate “P” and Silica “Si”), 2 phytoplankton compartments (Diatoms “D” and Cyanobacteria “CB”) and a grazer compartment “H”. Nutrient inputs are conditioned by a dam flow discharges. Both phytoplankton groups assimilate N and P, Silica is taken up only by diatoms. Nutrient assimilation is conditioned by light limitation “LL” modeled as a sinusoidal function. Herbivore grazing concerns both phytoplanktons, preferentially upon diatoms. The Nitrogen compartment is regenerated by Herbivore releases. All biological state variables are affected by mortality process eliminating the relative biomass from the system. The model parameterization is a key step for a successful implementation of a mechanistic model and the assessment of its prediction capability. Biological parameters were mainly derived from field experiments conducted on the Guadiana estuary, measurements form available data for the region as well as from other relevant literature data.

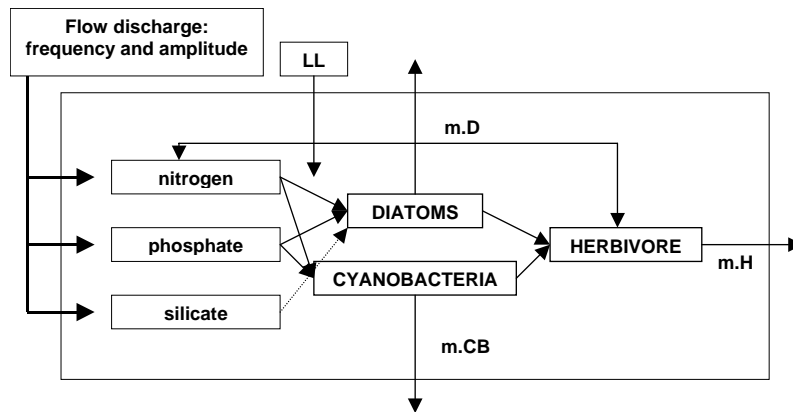

**Figure 1.** Conceptual model to be used in this course. Model structure with state variables and processes linking them. (Nitrogen “N”, Phosphate “P” and Silica “Si”, Diatoms “D” and Cyanobacteria “CB”, grazer compartment “H” light limitation “LL”).

**3. Materials and equipment**

**a) Hard and software requirement**

You will need a personal computer PC or Macintosh with the Matlab software (Matlab 5.1 or later, mathworks Inc.) installed. This model is working with **MATLAB®** or with the **Public shareware Octave** (the MATLAB® clone)<sup>1</sup>. After confirming that your PC is sharing one of these products, copy-paste the directory (Folder: “BottomUp\_model”) included into the CD delivered with this guide into the work directory of **MATLAB®** (or **Octave**) (ex. C:\MATLAB6p5\work) Model files are provided in the CD in the folder “BottomUp\_model” and are possibly modified for experienced Matlab® programmer.

**b) Safety information**

*Beware of touching electric devices with your hands wet. Be very careful when using all electric equipments.*

**4. Experiment description**

**STEP 1.** In the MATLAB “command window” type: `bottomup`, as shown in the **Figure 2**; this

<sup>1</sup> To make Octave MATLAB-compatible, put the following statements in your `~/.octaverc` file. This is a partial list of the user preference variables that should be changed to get MATLAB-compatible behaviour:  
`do_fortran_indexing = 'true';`  
`treat_neg_dim_as_zero = 'true';`  
`empty_list_elements_ok = 'true';`  
`implicit_str_to_num_ok = 'true';`  
`whitespace_in_literal_matrix = 'traditional';`  
`prefer_zero_one_indexing = 'true'.`

action will open the interface “Limitation Model” shown in the **Figure 3**.

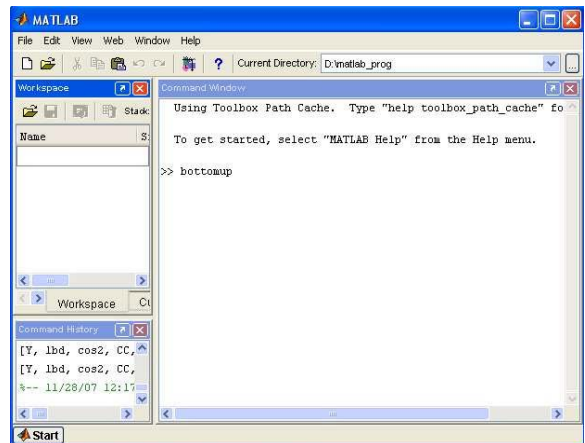

**Figure 2.** Command window of the MATLAB at STEP 1.

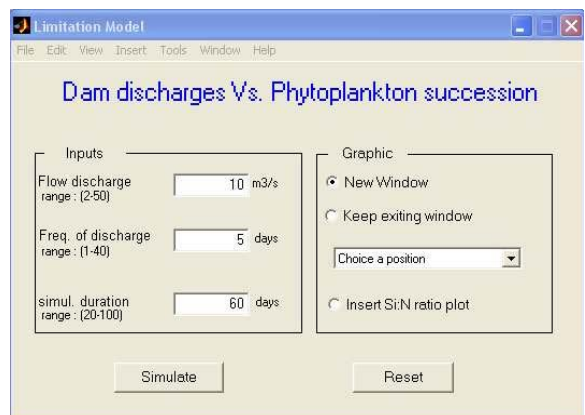

**Figure 3.** The *bottom up* model interface.

**STEP 2.**

Set values for the Flow discharge and Frequencies as presented in the **Table 1**. simulation duration can be fixed to 60 days. Mean flow for the entire duration is always...? You can keep the same window between the four different simulations thus a direct visual comparison of model outputs can be contemplated. To do so, activate the “Keep existing window” option and select the desired position for the coming simulation graphic. comparison of model outputs can be contemplated. To do so, activate the “Keep existing window” option and select the desired position for the coming simulation graphic. comparison of model outputs can be contemplated. To do so, activate the “Keep existing window” option and select the desired position for the coming simulation graphic. In order to add the Si:N ratio variations as a function of time (dam discharge frequency and amplitude) to the desired graphical outputs you can check the “Insert Si:N ratio plot”.

**Table 1. Setting values for the first group of simulations.**

Run 1 settings	Flow discharge	Frequency of discharge
Run 1.1	5	1
Run 1.2	20	4
Run 1.3	40	8
Run 1.4	60	12

**STEP 3.**

Set values for the Flow discharge and Frequencies as presented in the **Table 2**; simulation duration can be fixed to 60 days. As for the Step 2 you can keep the same window between the four different simulations and/or over-plot the Si:N ratio.

**Table 2. Setting values for the second group of simulations.**

Run 2 settings	Flow discharge	Frequency of discharge
Run 2.1	2	1
Run 2.2	2	2
Run 2.3	1	1
Run 2.4	1	2

**STEP 4.**

Set values for the Flow discharge and Frequencies as presented in the **Table 3**; simulation duration can be fixed to 60 days. As for the **STEP 2** you can keep the same window between the four different simulations and/or over-plot the Si:N ratio.

**Table 3. Setting values for the third group of simulations.**

Run 3 settings	Flow discharge	Frequency of discharge
Run 3.1	50	30
Run 3.2	50	15
Run 3.3	50	7
Run 3.4	50	1

You can export the simulation outputs as a picture common file (jpeg or other) for future consultation or to compose your course report. To export the figure you should select the export option in the File menu as shown in **Figure 4**.

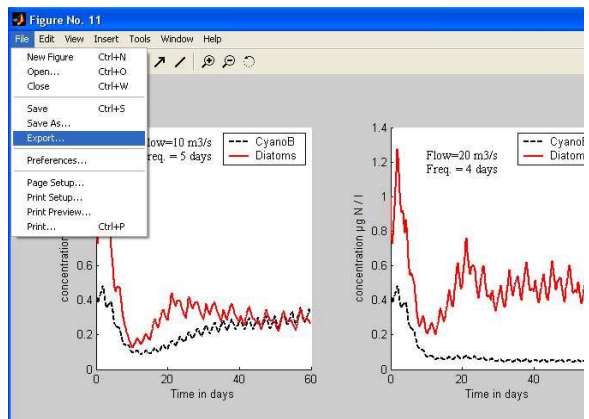

**Figure 4. To export simulation outputs into common a picture file.**

**5. Organizing the data**

No data generated.  
No statistics.  
Graphs already obtained.

**6. Analysing the results**

In STEP 2 the mean flow for the entire duration is always 5m3/s (since the duration of a unique discharge is 24h.

1. Where there significant differences in response from different settings?

2. In which case cyanobacterial community is dominating?
3. Does the Si:N ratio always superior than 0? Why?
4. Did the diatom response function of the changes on Si:N ratio?
5. In STEP 3 you simulated the phytoplankton response to reduced ecological minimum flow.
6. What are the general findings in terms of cyanobacterial dominance risks?
7. For which minimum flow is it possible to reduce this risk?

In STEP 4 you simulated the temporal phytoplankton communities changes to a high discharge flow of 50m<sup>3</sup>/s with different temporal intervals, respectively for 30, 15, 7 and 1 days.

1. Considering also the STEP 2 simulations, which is the most important factor: flow amplitude or frequency?

## 7. Discussion

1. Is the phytoplankton succession dependent on a unique limiting nutrient or on the relative importance between nutrient forms?
2. Using the model as a decision support system, what are the pairs of flow discharge amplitude and frequency that guarantee the dominance of diatoms vs. cyanobacterial communities?
3. Regulation of river discharge needs to consider not only the quantity of water, but also the timing of the release. What are the consequences for such findings in terms of natural river flow variability (occurrence of harmful algal blooms HAB)?

## REFERENCES

1. Carlsson P., Granéli E. 1999. Effects of N:P:Si ratios and zooplankton grazing on phytoplankton communities in the northern Adriatic Sea. II. Phytoplankton species composition. *Aquatic Microbial Ecology*. 18: 55-65.
2. Chicharo L. Chicharo M. A., Ben-Hamadou R. 2006. Use of a hydrotechnical infrastructure (Alqueva Dam) to regulate planktonic assemblages in the Guadiana estuary: basis for sustainable water and ecosystem services management. *Estuarine Coastal and Shelf Science*. 70 (1-2):3-18.
3. Chicharo L., Ben-Hamadou R., Amaral A., Range R., Mateus C., Piló D., Marques R., Chicharo M.A. Application and demonstration of the Ecohydrology approach for the sustainable functioning of the Guadiana estuary (South Portugal). *Ecohydrology and Hydrobiology (in press)*.
4. Rocha C., Galvao H., Barbosa A. 2002. Role of transient silicon limitation in the development of cyanobacteria blooms in the Guadiana estuary, south-western Iberia. *Marine Ecology Progress Series* 228:35-45.
5. Wolanski E., Chicharo L., Chicharo M., Morais P. 2006. An ecohydrology model of the Guadiana Estuary (South Portugal). *Estuarine, Coastal and Shelf Science* 70(1-2):132-143.
6. Zalewski M. 2000. Ecohydrology-the scientific background to use ecosystem properties as management tools toward sustainability of water resources. *Guest Editorial in Ecological Engineering* 16:1-8.

## 14. TOP-DOWN EFFECTS - REGULATION OF BIOTIC FEEDBACKS BY HYDROLOGY.

### Chapter Objectives

Evaluation the role of hydrology in regulation feedbacks between fish fry, zooplankton and algal blooms.

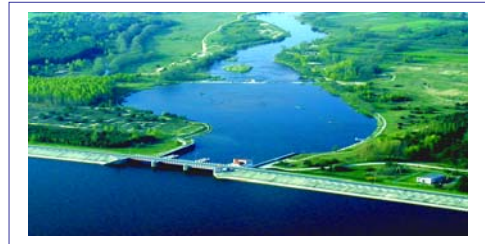

Sulejow Reservoir (photo ERCE)

**EH principle: 1 – identification of processes, 3 – dual regulation (biota by hydrology)**

### INTRODUCTION

The general question in formulation of Ecohydrology concept was how to regulate biological processes of freshwater ecosystem using hydrology and vice versa how to use biotic ecosystem properties as tool in water management (Zalewski 2000). Both should serve as a reference system for enhancement of the absorbing capacity of ecosystems against human impact by using ecosystem properties as management tool. This in turn depends on the development dissemination and implementation of interdisciplinary knowledge based on the recent progress in environmental sciences. Eutrophication of reservoirs and its effect toxic algal bloom due to complicated pattern is one of the most difficult to solve problems due to complicated feedbacks appearing in the catchment above reservoirs (Zalewski 1992, Zalewski 1999).

### ELABORATING THE EXPERIMENT

#### 1. General description

Ecohydrology solution - hydrology manipulation to regulate biotic feedbacks is used in changing allocation of excessive phosphorus provided to reservoir from the catchment, in reservoir trophic cascade. This refer to Ecohydrology Hypothesis 1: "The regulation of hydrological parameters in an ecosystem or catchment can be applied for controlling biological processes" (Zalewski 2000).

The first of three major key principles of ecohydrological approach – regulation biological cascade by hydrological manipulation is exemplified by case in Sulejow Reservoir (Zalewski *et al.* 1990 a, 1990b) (Figure 1).

During eutrophication fishes depend for food on the limnetic zone, but still reproduce in littoral. So in eutrophication reservoirs where planktonic food is not limited, the reproductive success of cyprinids, percids and centrarchids depends mostly on spawning substrata, especially on the extent to which shore vegetation is flooded.

Following flooding of the shoreline herbal vegetation, fry survival was high, large zooplankters were drastically reduced, planktonic algal biomass increased sharply, and water quality declined. Due to overcrowding, intra- and interspecific competition among fry was high, resulting in mass shoreline migration, 30% growth retardation, and low overwinter survival. The scarcity of large zooplankters reduced growth so much in pike-perch fry (*Stizostedion lucioperca* L.) that they were not big enough to eat even the slow growing perch (*Perca fluviatilis* L.) and roach fry (*Rutilus rutilus* L.) at the time the pike-perch would normally become piscivores in mid-July. The consequent lack of one generation of such an easily over-exploitable species might reduce its population density seriously for many years.

So, in temperate lowland reservoirs the reproductive success of dominant fish species could be regulated by their access to the shoreline ecotone by hydrology regulation on dam. By enhancing piscivores to reduce the planktivores fish populations (Hrbacek *et al.* 1961; Shapiro *et al.* 1975), the density of efficient large filtering zooplankton (e.g. cladocerans) can be increased, and the quality of stagnant water improved (Figure 1).

#### 2. Materials and equipment

##### a) Field experiments

- beach seine net 10m long 150 cm high;
- materials and equipment to collect fish samples and samples of zooplankton;

- clothing: water proof boots and safety jacket.

**b) Data analysis**

- computer;
- data sheet organizer;
- basic graphic software.

**Safety information**

Check the weather forecast before going to the field. Use appropriate clothing. Do not walk into deeper water or enter a boat wearing your water proof boots. Beware of touching electric devices with your hands wet. Be very careful when using all electric equipments.

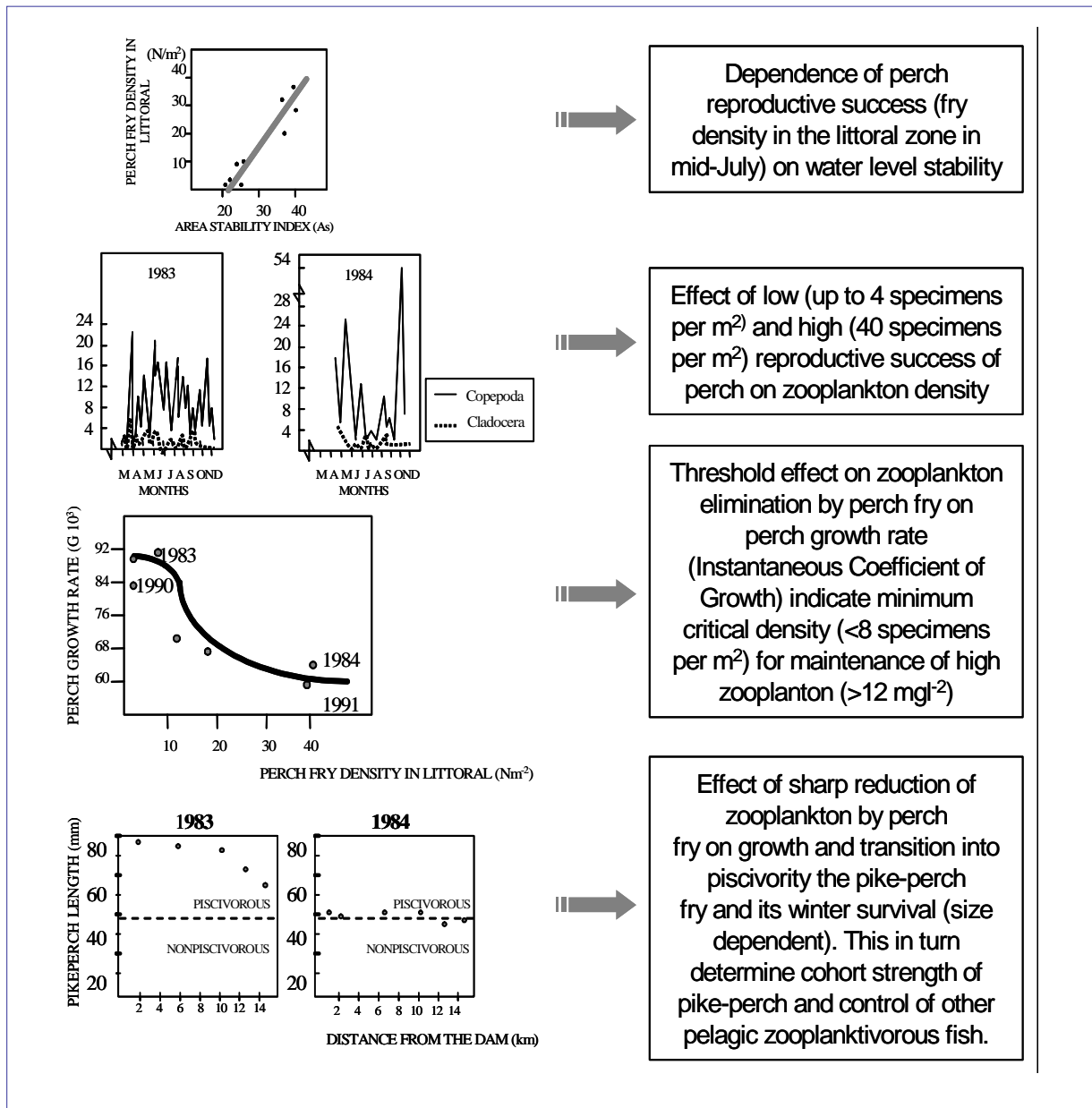

**Figure 1.** The Sulejow Reservoir case - the influence of shoreland flooding on fish and zooplankton (data from Zalewski et al. 1990a, 1990b).

**3. Experiment description**

**STEP 1.** Training the fishing person in moving slowly and carefully to learn how to reduce the distance of avoidance fishing person by fish fry below 3 meters (**Figure 2**).

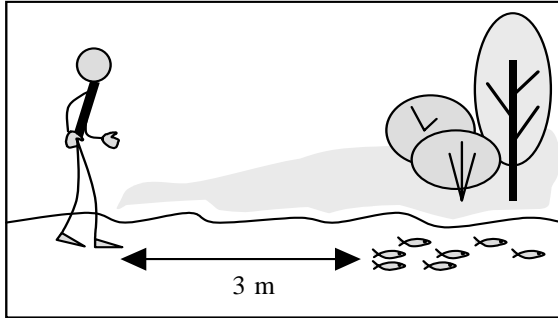

**Figure 2.**

**STEP 2.** Taking fish fry samples along the shoreline by using the beach seine net in the manner presented at **Figure 3 (Photo 1)**, on typologically different shoreline sites (e.g. in reservoir near the dam and in its middle part).

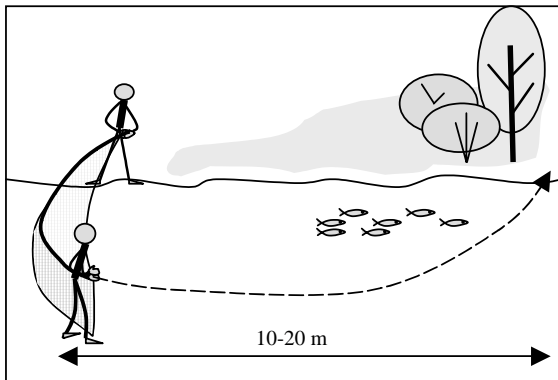

**Figure 3.**



**Photo 1.** Beach seining (photo A. Wojtal-Frankiewicz).

**STEP 3.** As far as major energy flow in ecosystem is through dominants, the 3 sub-samples of fish fry for gut content analysis should be taken (3x10 specimens of dominant species each and 3x3 specimens of subdominant species each); other fish should be released after being counted.

**STEP 4.** Analysis of 24 hour pattern pressure on zooplankton - fish samples every 4 hours at selected representative stations should be taken. The reduction of zooplankton (large Cladocera) in years of low fish fry density (**A**) and high fish fry density (**B**) is reflected in stomach content and foraging strategy (**Figure 4AB**).

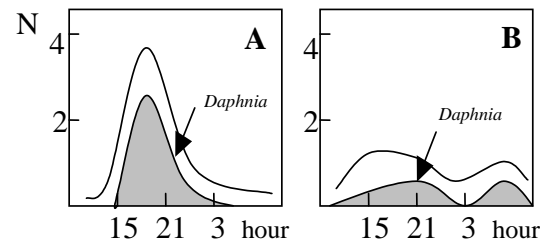

**Figure 4 AB.**

**STEP 5.** Samples for estimation the density of zooplankton.

**4. Organizing the data**

**Organizing the data**

Determination of species in each sample should be done. Number of specimens of particular species should be counted, the **weight (w)**, **total length (Lt)**, **body length (Lc)** should be taken (**Table 1**).

**Table 1.** Fish species sampled.

Number	Weight (w) (g)	Lt (mm)	Lc (mm)
1			
2			
...			
<b>Average</b>	...	...	...

The stomach content analysis should be done for sub-samples (**Table 2**).

**Table 2.** *Fish food content.*

Specimen No	1	2	...	Average
Food category				
	%	%	%	
e.g. <i>Daphnia</i> sp.				
e.g. <i>Bosmina</i> sp.				
...				
<b>Stomach fullness</b>				

**Basic statistical analysis**

Average weight, Lt, Lc and standard deviation of these values should be calculated.

**Stomach fullness (weight of food/body weight)** should be calculated for each specimen and comparison of these values from different sites in 24 hour cycle with zooplankton density from the same sites should be done.

Statistical comparison of data should be done.

**Making graphs**

For each species graphic model of food content in 24 hour cycle on each shoreline site should be prepared and compared for at least 2 stations.

**5. Analysing the results**

Comparison of data obtained during the experiment with data from the data bank (see **Figure 5**).

**6. Discussion**

1. How would you verify hypothesis about migration of fish in 24 hour cycle?
2. What kind of differences in the pattern of stomach fullness and content indicate intensity of pressure on filtering zooplankton?
3. If you have to do this experiment again, what would you change? Why?

**REFERENCES**

1. Hrbacek J., Dvorakova M., Korinek V., Prochazkova L. 1961. Demonstration of the effect of the fish stock on the species composition of zooplankton and the intensity of metabolism of the whole plankton association. *Verh. Internat. Verein. Limnol.* 14: 192-195.
2. Shapiro J., La Marra V., Lynch M. 1975. Biomanipulation: An ecosystem approach to lake restoration. *In: P.L. Brezonik, J.L. Fox (eds.). Water Quality Management through Biological Control.* Gainesville, FL: Dept. of Env. Eng. Sciences, Univ. Florida. 85-96 pp.
3. Zalewski M., Brewinska-Zaras B., Frankiewicz P. 1990a. Fry communities as a biomanipulating tool in a temperate lowland reservoir. *Arch. Hydrobiol. Beih. Ergebn. Limnol.* 33:763-774.
4. Zalewski M., Brewinska-Zaras B., Frankiewicz P., Kalinowski S. 1990. The potential for biomanipulation using fry communities in a lowland reservoir: Concordance between water quality and optimal recruitment. *Hydrobiologia* 200/201:549-556.
5. Zalewski M. 1992. Percid fish as a tool for restoration of reservoir ecosystem, improvement of water quality and optimalization of fishery yield. *In: Aquaculture and Schistosomiasis. Proceedings of a Network Meeting, Manila, Phillipines, 6-10 Aug 1991, National Academy Press, Washington, D.C.* 148-157 pp.
6. Zalewski M. 1999. Minimising the risk and amplifying the opportunities for restoration of shallow reservoirs. *In: D. M. Harper, B. Brierley, A.J.D. Ferguson, G. Phillips (eds.). The Ecological Bases for Lake and Reservoir Management.* *Hydrobiologia* 395/396:107-114.
7. Zalewski M. 2000. Ecohydrology - the scientific background to use ecosystem properties as management tools toward sustainability of water resources. *Guest Editorial in Ecological Engineering* 16:1-8.

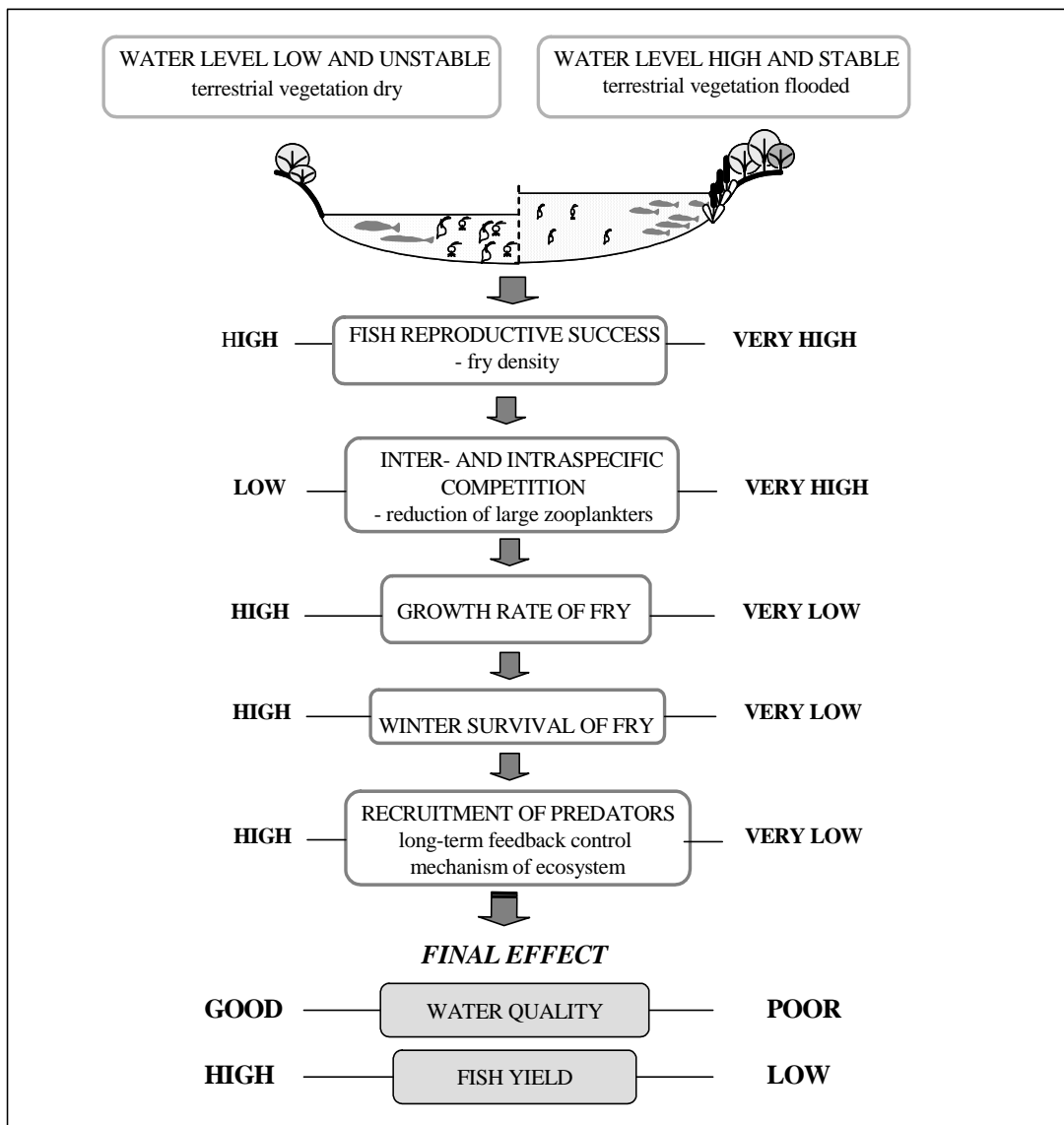

**Figure 5.** A Synthesis - the influence of shoreland flooding on fish, zooplankton, and water quality (data from Zalewski et al. 1990a, 1990b).



## 15. ANALYSIS OF JUVENILE FISH BEHAVIOUR IN DIFFERENT HYDROLOGICAL CONDITIONS.

### Chapter Objectives

To demonstrate how hydrological conditions (low or high water flow) may influence:

- Spatial distribution of juvenile fish among different habitats;
- Growth rate of juvenile fish due to changes in feeding strategies and in the output of inter- and intra-specific competition.



*Perca fluviatilis*, perch (photo ERCE)

**EH principle: 1 – identification and quantification of processes, 3 – dual regulation**

### INTRODUCTION

Hydrological regime may highly influence fish behaviour insisting them to adjust both habitat choice and feeding strategies to water discharge pattern (Bunt *et al.* 1999). Additional energetic costs of facing unfavorable conditions may be crucial for fish survival, especially juvenile ones. Man made reservoirs contain specific mixture of fish species, characteristic for both riverine and lacustrine environments (Fernando, Holcik 1991). Thus depending on the water discharge one may expect different competitive ability of these fish species influencing the final structure of their community. Knowledge on fish responses to different hydrological conditions may be used for manipulating community structure and controlling top-down effect in water bodies (Zalewski *et al.* 1990).

### ELABORATING THE EXPERIMENT

#### 1. General description

The habitat choice and/or feeding mode of juvenile fish will be observed in simple indoor glass artificial streams with regulated water flow, consisted of at least one riffle-pool sequence. Fish position in the stream and utilization of offered food (drifting invertebrates) will be recorded by video-system or/and noticed directly by observers.

#### 2. Experimental design

At least seven specimens of the same size of each of two/three fish species: e.g. **perch**, **roach** and **bleak** will be introduced to the artificial

stream. The **behaviour of juvenile fish** will be estimated by the differences in both spatial distribution and feeding activity depending on water velocity. Observations will be focused on the position of fish: **riffle or pool** (see **Figure 1**) (if there are only one riffle and one pool riffle should be close to the water inlet).

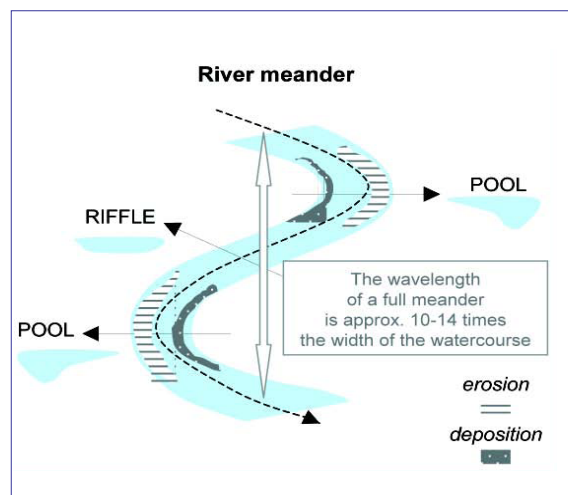

**Figure 1.** *The pool- riffle sequence in river.*

Proportion of time spent in given habitat during the observation will be calculated for each individual fish, distinguishing between periods when fish were fed with drifting food and when there was no food offered. Simultaneously, the number of attacks on drifting prey will be notified for individual fish and standardized by dividing it by observation time.

To establish conditions which will favor food competition fish should be fed on suboptimal rations (e.g. prey to fish biomass ratio - 1:100).

The **condition factor (K)** (equation 1 see Annex) and **growth rate** measured as a difference between initial and final fish weight will be compared between selected water discharges for each species. Additionally, stomach (for predators) or foregut contents (for Cyprinids) on the end of the experiment will be analysed to find out differences in consumed prey numbers.

### 3. Materials and equipment

#### a) Field experiments

You will need materials and equipment to collect zooplankton and fish (unless they are available from fish-culture):

- small beach seining net and two pairs of waders;
- plankton net with a 100 mm mesh size;
- anaesthetics;
- baskets and containers for water, zooplankton and fish and transport to the lab (you may need an oxygen pump if it is hot weather and/or transport time is long).

#### b) Laboratory experiments

You will need to use lab with experimental flow-through glass stream(s) supplied with water and oxygen pumps.

To observe habitat use by fish and their feeding rate you will need:

- video camera and video player;
- stop-watches;
- live food used for fish feeding: field-collected natural food (zooplankton) or commercially obtained *Artemia salina*.

To analyze fish food you will need:

- anaesthetics;
- fish dissection kits and binoculars for gut contents counting.

#### c) Data analysis

- computer;
- data sheet organizer;
- basic graphic software.

### 4. Data organizing and analysis

#### Organizing the data

Observations (separately for spatial distribution, feeding behaviour, gut contents and growth rate) will be gathered into data sheets (see Table 1-4 in Annex).

#### Basic statistical analysis

T-student test or its nonparametric alternatives will be used for comparing fish spatial distribution, their feeding intensity, and growth rate.

#### Making graphs

Results will be presented in form of figures and tables.

### 5. Analysing the results

The following questions should be answered on the basis of achieved data:

1. Are there intra- and inter-specific differences in fish spatial distribution in the stream depending on water discharge and feeding/not feeding events?
2. Are there intra- and inter-specific differences in fish feeding intensity depending on water discharge?
3. Are above differences detectable in fish condition factor and their growth rate?
4. Which part of the experiment should be changed in the future and what additional questions should be asked?

### REFERENCES

1. Bunt C.M., Cooke S.J., Katopodis C., McKinley R.S. 1999. Movement and summer habitat of brown trout (*Salmo trutta*) below a pulsed discharge hydroelectric generating station. *Regulated Rivers: Research and Management* 15:395-403.
2. Fernando C.H., Holcik J. 1991. Fish in Reservoirs. *Int. Revue ges. Hydrobiol.* 76: 149-167.
3. Zalewski M., Brewińska-Zaraś B., Frankiewicz P., Kalinowski S. 1990. The potential for biomanipulation using fry communities in a lowland reservoir: concordance between water quality and optimal recruitment. *Hydrobiologia* 200/201:549-556.

### ANNEX

equation 1: *Condition factor formula*

$$K = w \text{ Lt}^{-3}$$

Where:

**K** - condition factor

**w** - fish weigh [g]

**Lt** - fish total length [cm]

**Table 1. Fish position data sheet.**

$T_r$  – time [min] spent in **riffle** during a giving trail  
 $T_p$  – time [min] spent in **pool** during a giving trail

Discharge Specimens		Low water velocity			High water velocity		
		Fish species			Fish species		
		1	2	3	1	2	3
1	$T_r$ $T_p$						
2	$T_r$ $T_p$						
3	$T_r$ $T_p$						
4	$T_r$ $T_p$						
5	$T_r$ $T_p$						
6	$T_r$ $T_p$						
7	$T_r$ $T_p$						
Av	$T_r$ $T_p$						
SD	$T_r$ $T_p$						

**Table 4. Gut contents data sheet.**

$N_p$  – number of pray

Discharge Specimens		Low water velocity			High water velocity		
		Fish species			Fish species		
		1	2	3	1	2	3
1	$N_p$						
2	$N_p$						
3	$N_p$						
4	$N_p$						
5	$N_p$						
6	$N_p$						
7	$N_p$						
Av							
SD							

**Table 2. Fish feeding rate data sheet.**

$N_{att}$  – number attacks

Discharge Specimens		Low water velocity			High water velocity		
		Fish species			Fish species		
		1	2	3	1	2	3
1	$N_{att}$						
2	$N_{att}$						
3	$N_{att}$						
4	$N_{att}$						
5	$N_{att}$						
6	$N_{att}$						
7	$N_{att}$						
Av							
SD							

**Table 3. Fish growth data sheet.**

$W$  – fish weigh [g]

Discharge Specimens		Low water velocity			High water velocity		
		Fish species			Fish species		
		1	2	3	1	2	3
1	$W_1$						
2	$W_2$						
3	$W_3$						
4	$W_4$						
5	$W_5$						
6	$W_6$						
7	$W_7$						
Av							
SD							



## 16. FISH COMMUNITY AS A TOOL IN ENVIRONMENTAL QUALITY ASSESSMENT.

### Chapter Objectives

To demonstrate how to assess the river ecosystem quality status with use of fish-based method (European Fish Index – EFI).



*Leuciscus idus (ide)* (photo: R. Kujawa)

**EH principle: 1 – use of biota as impact indicator**

### INTRODUCTION

Biological quality elements, supported by hydro-morphological, chemical and physico-chemical elements, are currently worldwide used to assess ecological quality of water ecosystems. Ecologically-orientated, sustainable management of water bodies is also the European Union course in water policy (Water Framework Directive - WFD, 2000/60/EC) that forces Member States to protect, enhance and restore all surface water bodies with the aim of achieving good chemical and ecological status till the year 2015.

For rivers five biological quality elements may serve as indicators of their ecological status: phytoplankton, macrophytes, phytobenthos, benthic invertebrate fauna, and fish fauna.

**Fish as integrators at the highest trophic level in water ecosystems reflect both aquatic and its surrounding watershed condition (Karr 1981), thus broaden management objectives towards the river basin perspective required in WFD.** The use of biota, especially fish, as the efficient diagnostic and management tool in Integrated Water Resources Management (IWRM) is widely promoted by the **ecohydrological approach**. The integrating of understanding of water and biota interplay at a catchment scale (1<sup>st</sup> - hydrological principle of the Ecohydrology Concept (EH) resulted in EH methodology based on 'dual regulation' thus: of biota by altering hydrology, and of hydrology by shaping biota (3<sup>ed</sup> - ecological engineering principle of the EH) what might be effectively used in river restoration (Zalewski 2000, Zalewski ed. 2002, Lapinska *et al.* 2002, Zalewski & Wagner-Łotkowska eds 2004, Lapinska *et al.* 2004ab, Verdonschot *et al.* 2006, de Leeuw *et al.* 2007, Winter *et al.* 2008).

### ELABORATING THE EXPERIMENT

#### 1. General description

**Attributes of fishes essential in ecological status assessment of rivers (FAME project, <http://fame.boku.ac.at>):**

- presence in almost all water bodies;
- well known taxonomy;
- well known life history;
- well known ecological requirements;
- available historical information;
- high habitat preferences - indicative for habitat quality;
- migratory behavior - indicative of river continuum/river connectivity conditions;
- as top predators subsume trophic conditions across a food chain;
- as members of a specific trophic guild, provide detailed information on respective trophic levels;
- longevity - indicative for long time periods;
- long tradition of fishery and sport fishing in which fishes have been used as indicators for water quality;
- high economic and aesthetic value helpful in river protection and conservation planning.

The principle of biological assessment of ecological status of water bodies is to measure the deviation of the current situation from (nearly) undisturbed **river-type-specific reference conditions with reference e.g. fish community** and to assign the correct quality level in a **5-tiered scheme** formulated in the WFD (**Figure 1**).

**Figure 1.** Ecological status assessment of rivers according to WFD.

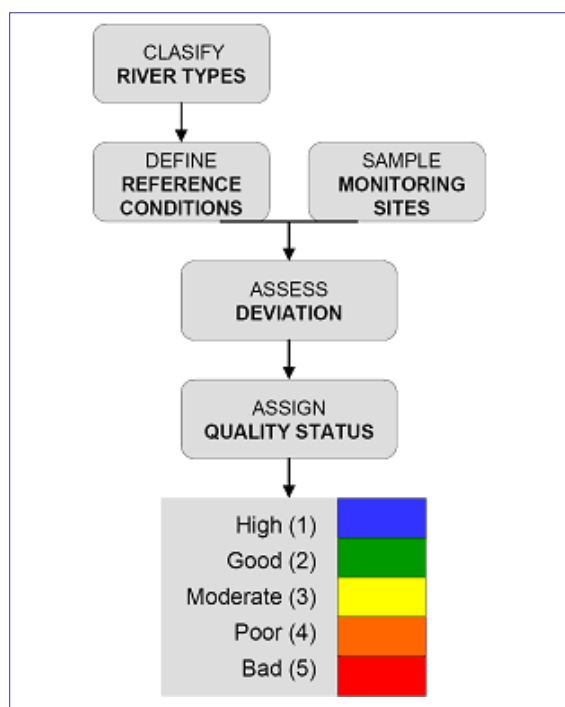

## 2. Experiment design

The **European Fish Index (EFI)** is a site-specific method based on a predictive model that derives reference conditions for individual sites and quantifies the deviation between predicted and observed conditions of the fish fauna. The ecological status is expressed as an index ranging from 1 (**high ecological status**) to 0 (**bad ecological status**). EFI was developed in a frame of EU EC FAME project and is proposed as one from the universal Europe wide assessment methods<sup>1</sup>, that are nowadays developing and testing (see FAME CONSORTIUM – Manual 2004 downloaded from the project web page <http://fame.boku.ac.at>).



<sup>1</sup> not to apply for large floodplain rivers and Mediterranean rivers dominated by endemic species.

## A. STEPS OF THE EFI METHODOLOGY

Eight steps of the EFI index methodology are presented in **Figure 2** (2.1, 2.2, 2.3, 2.4, 2.5, 2.6, 2.7, 2.8).

### STEP 1. Metric calculation

In the first step the EFI uses fish data from single-pass electrofishing to calculate the assessment metrics (**Figure 2.1**).

The EFI employs 10 metrics belonging to the following ecological functional groups: trophic structure, reproduction guilds, physical habitat, migratory behaviour and capacity to tolerate disturbance in general (**Table 1**).

**Table 1.** The 10 metrics used by the EFI and their response to human pressures.

(↓ = decrease; ↑ = increase of metric)

EFI metrics	metrics response
<b>Trophic level</b>	
1. Density of insectivorous species	↓
2. Density of omnivorous species	↑
<b>Reproduction strategy</b>	
3. Density of phytophilic species	↑
4. Relative abundance of lithophilic species	↓
<b>Physical habitat</b>	
5. Number of benthic species	↓
6. Number of rheophilic species	↓
<b>General tolerance</b>	
7. Relative number of intolerant species	↓
8. Relative number of tolerant species	↑
<b>Migratory behaviour</b>	
9. Number of species migrating over long distances	↓
10. Number of potamodromous species	↓

### STEP 2. Metric prediction

In the second step a theoretical reference value, indicating no or only slight human disturbances (equals high or good status = reference), is predicted for each metric using environmental variables by means of a multilinear regression model calibrated with reference data (**Figure 2.2**).

Ten environmental factors, three sampling variables and sampling strategy information are used to predict reference values for selected site. Additional information on location, site name, sampling date required for the analyses shows **Table 2**.

### STEP 3. Residual calculation

The residuals of the multilinear regression models are used to quantify the level of degradation. Residuals are calculated as observed metric values minus theoretical (predicted) metric values (**Figure 2.3**).

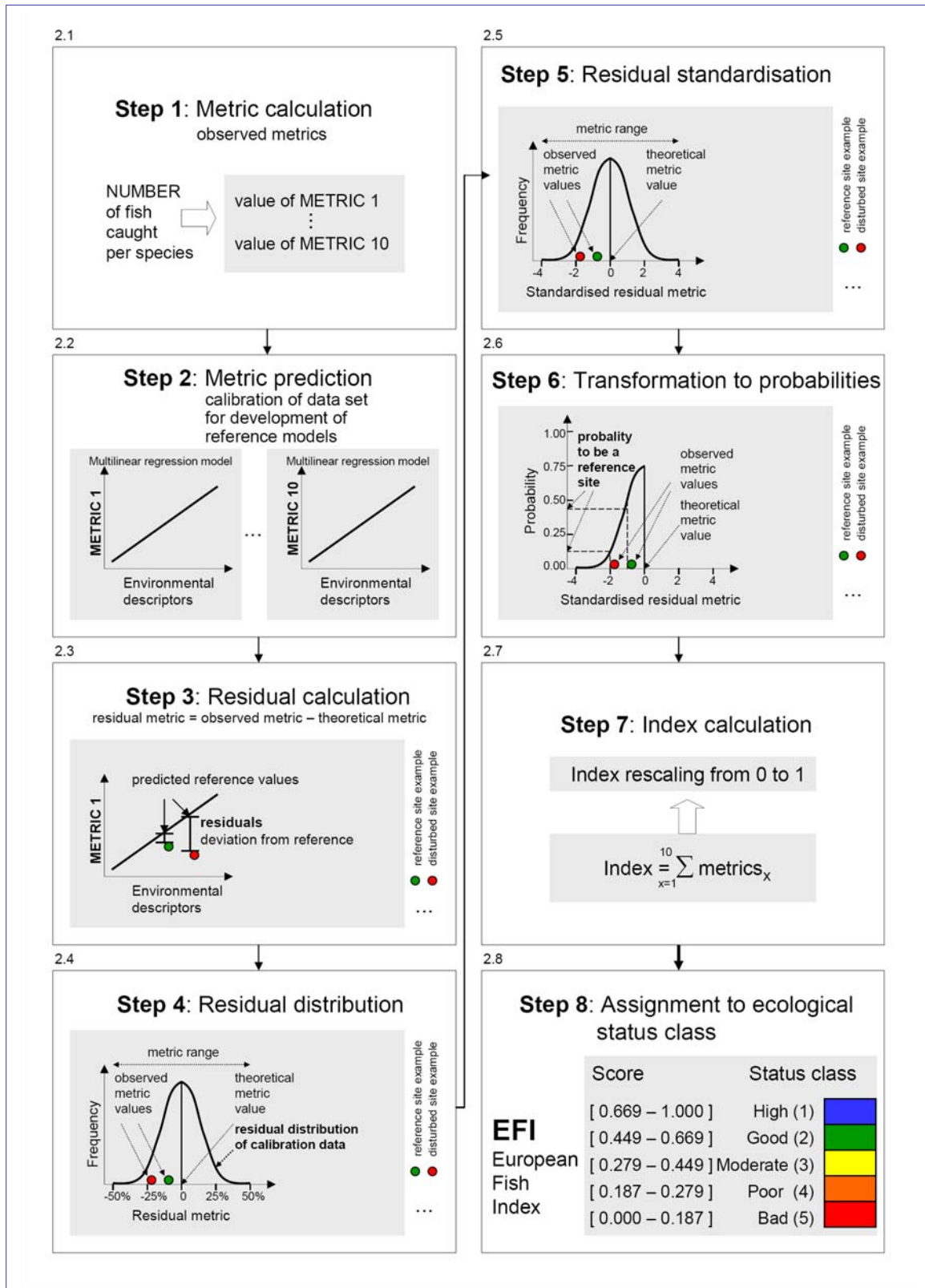

Figure 2. (2.1, 2.2, 2.3, 2.4, 2.5, 2.6, 2.7, 2.8). Steps of the EFI index methodology.

**Table 2.** *Abiotic variables and sampling method variables required for the EFI to predict reference conditions (italics - variable codes for the EFI software, (\*) - variables to predict the European Fish Types – see 6.3.1 and Table 5).*

<b>Environmental variables describing the sampling site</b>	
1. Altitude* <i>E_altitude</i>	The altitude of the site in metres above sea level (data source: maps).
2. Lakes upstream <i>E_lakeupstream</i>	Are there natural lakes present upstream of the site? Answer <b>Yes</b> or <b>No</b> . Only applicable if the lake affects the fish fauna of the site, e.g. by altering thermal regime, flow regime or providing seston.
3. Distance from source* <i>E_distsource</i>	<b>Distance from source in kilometres</b> to the sampling site measured along the river. In the case of multiple sources, measurement shall be made to the most distant upstream source (data source: maps).
4. Flow regime <i>E_flowregime</i>	<b>Permanent:</b> never drying out. <b>Summer dry:</b> drying out during summer (data source: gauging station or hydrological reports).
5. Wetted width* <i>E_wettedwidth</i>	<b>Wetted width in metres</b> is normally calculated as the average of several transects across the stream. The wetted width is measured during fish sampling (performed mainly in autumn during low flow conditions) (data source: field measurement).
6. Geology <i>E_geotypo</i>	<b>Siliceous</b> or <b>calcareous</b> (based on dominating category) (data source: geological maps).
7. Mean air temperature* <i>E_tempmean</i>	<b>Yearly average air temperature measured for at least 10 years.</b> Given in degrees Celsius (°C) (data source: nearby measuring site, interpolated data).
8. Slope* <i>E_slope</i>	<b>Slope of streambed along stream expressed as per mill, m/km (‰).</b> The slope is the drop of altitude divided by stream segment length. The stream segment should be as close as possible to 1 km for small streams, 5 km for intermediate streams and 10 km for large streams (Data source: maps with scale 1:50 000 or 1:100 000).
9. Size of catchment <i>E_catchclass</i>	<b>Size of the catchment (watershed) upstream of the sampling site.</b> Classes are: <10, <100, <1000, <10 000, >10 000 km <sup>2</sup> .
10. River region <i>E_riverregion</i>	To define the river region use <b>table and map in FAME CONSORTIUM – Manual (p.60-61).</b>
<b>Variables describing the sampling methods</b>	
11. Sampling strategy <i>E_strategy</i>	Definition of how the section was sampled. Whole river width ( <b>Whole</b> ) or only parts of the river ( <b>Partial</b> ).
12. Method <i>E_method</i>	Define if electric fishing was carried out by wading ( <b>Wading</b> ) or boat ( <b>Boat</b> ).
13. Fished area <i>E_fishedarea</i>	Area of the section that has been sampled ( <b>sampled length * sampled width</b> ) given in m <sup>2</sup> .
<b>Variables describing the location, name of site and date of fishing</b>	
14. Site code <i>E_sitecode</i>	Unique reference number per sampling site. <b>User defined schemes.</b>
15. Date <i>E_date</i>	Day/Month/Year e.g. <b>23/04/2004.</b>
16. Latitude <i>E_latitude</i>	Latitude is given in degrees followed by a decimal point and than minutes and seconds, two digits each. It is always followed by N (e.g. <b>51.1927N</b> ) (data source: GPS, digital maps).
17. Longitude <i>E_longitude</i>	Longitude is given in degrees followed by a decimal point and than minutes and seconds, two digits each. It is always followed by E or W (e.g. <b>4.5509 E</b> ) (data source: GPS, digital maps).
18. X* <i>E_x</i>	X co-ordinate decimal unit WGS84 (e.g. <b>52.5314</b> ) (data source: GPS, digital maps).
19. Y* <i>E_y</i>	Y co-ordinate decimal unit WGS84 (e.g. <b>00.5219</b> ) (data source: GPS, digital maps).
20. River name <i>E_rivername</i>	The <b>official name</b> used in your country.
21. Site name <i>E_sitename</i>	Location name e.g. indicating a <b>nearby town or village.</b>

**STEP 3. Residual calculation**

The residuals of the multilinear regression models are used to quantify the level of degradation. Residuals are calculated as observed metric values minus theoretical (predicted) metric values (**Figure 2.3**).

**STEP 4. Residual distribution**

Residual metric values scatter around the theoretical value. Disturbed sites has a greater deviation from the theoretical value, than undisturbed and by this are less likely to belong to the reference residual distribution (**Figure 2.4**).

**STEP 5. Residual standardisation**

The metrics in the EFI (Table 1) are based on different units (e.g. number of species, number of individuals, density) thus to make them comparable they are standardised through subtraction and division by the mean and by the standard deviation of the residuals of the reference sites, respectively (**Figure 2.5**).

**STEP 6. Transformation to probabilities**

Some standardised residuals values tend to increase with disturbance (i.e. density of omnivorous species), whereas others decrease (i.e. density of insectivorous species, Table 1), thus they are transformed into probabilities (**Figure 2.6**). After transformation all metrics will vary between 0 and 1, and all metrics will have the same response to disturbance. This final metric value describes the probability for a site to be a reference site (high and good). The site that fits perfectly with the prediction (theoretical value) will have a final probability metric value of 0.5, and if higher than 0.5 it is high quality reference. The probability value for disturbed site (moderate, poor, bad) will decrease when disturbance intensity increases.

**STEP 7. Index calculation**

The final European Fish Index (EFI) is obtained by summing the 10 metrics, and then by rescaling the score from **0** to **1**.

**STEP 8. Assignment to ecological status class**

The final step is to assign index scores to ecological status classes according to WFD. Class boundaries have been defined based on the comparison of data sets with different degrees of human pressures. The class boundaries for the five status classes are shown in **Figure 2.8**.

**B. STEPS FOR THE EFI APPLICATION**

Steps for the EFI index application are presented in **Figure 3**.

**STEP 1. Site selection**

The selected site should be representative, within the river segment, in terms of habitat types and diversity, landscape use and intensity of human pressures.

**River segment is defined as:**

- **1 km** for small rivers (catchment < 100 km<sup>2</sup>)
- **5 km** for medium-sized rivers (100-1000 km<sup>2</sup>)
- **10 km** for large rivers (> 1000 km<sup>2</sup>)

A segment for a small river will thus be 500 m upstream and 500 m downstream of the sampling site (1 km in total).

To model the **reference situation** for the sampled site the variables from **Table 2** should be recorded in the data sheet given in **Table 6** (see **Annex**).

In this exercise at least **3 sites** of different human impact should be selected for the analysis. It is advised to choose **1 good, 1 moderate and 1 poor quality class of the sampled river reach** with use of an expert judgment, and on the basis of hydro-geomorphological on-site observation. Examples of each quality site are shown on **Figure 4**.

Small size, wadable, river with good access to habitats will be best for education of the sampling method (**always perform by an electrofishing specialist**) and to test the index.

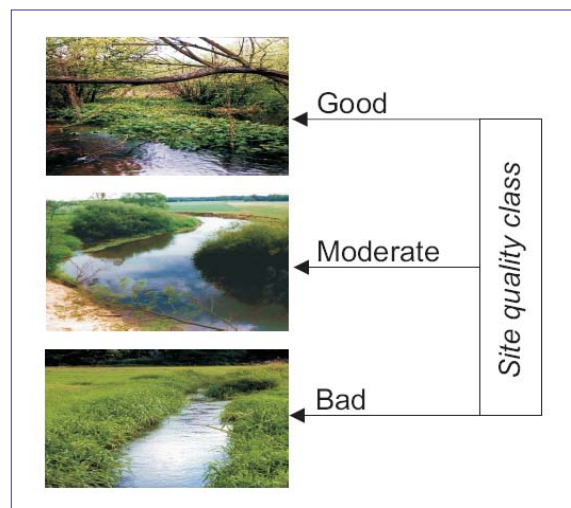

**Figure 4.** Examples of sampling sites to be used in experiment (photo K. Krauze).

### STEP 3. Fish sampling

To calculate the index only fish data caught by electrofishing can be used. Standardised electrofishing procedures are described in the CEN directive: "Water Analysis – Fishing with Electricity" (CEN document 2003 - EN 14011) both for wadable (depth < 0.7 m) and for non-wadable rivers (depth > 0.7 m) (Table 4).



The standard electrofishing equipment is presented in Figure 5. The selection of waveform, DC (Direct Current) or PDC (Pulsed Direct Current), depends on the conductivity of the water, the dimensions of the water body and the expected fish species. AC (Alternating Current) is harmful for the fish and can not be used. Fishing equipment must be suitable to sample small individuals (young-of-the-year).

Period advised for sampling is: late summer / early autumn.

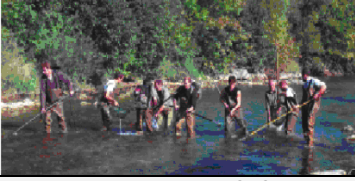

Figure 5. Electrofishing equipment (photo A. Bednarek).

Table 4. Fish sampling procedure.

Fish sampling procedure	Electrofishing in a wadable river (depth < 0.7 m)	Electrofishing in a non-wadable river (depth > 0.7 m)
1. Waveform selection	DC or PDC	DC or PDC
2. Number of anodes	one anode per 5 m width	depending on boat configuration
3. Number of hand-nets	each anode followed by 1 or 2 hand-nets (mesh size of 6 mm maximum) and 1 suitable vessel for holding fish	depending on boat configuration
4. Number of runs	one run	one run
5. Time of the day	daylight hours	daylight hours
6. Fishing length	10 - 20 times the wetted width, with a minimum length of 100 m	10 - 20 times the wetted width, with a minimum length of 100 m
7. Fished area	<ul style="list-style-type: none"> <li>river width &lt; 15 m: the whole site surface (Whole sampling strategy, see Table 2)</li> <li>river width &gt; 15 m: several separated sampling areas selected within a sampling site – minimum 1000 m<sup>2</sup> (Partial sampling strategy)</li> </ul>	both banks of the river or a number of sub-samples proportional to the diversity of the habitats present - minimum a 1000 m <sup>2</sup> (Partial sampling strategy)
8. Fishing direction	upstream	<ul style="list-style-type: none"> <li>normal flow: downstream in such a manner as to facilitate good coverage of the habitat, especially where weed beds are present or hiding places of any kind are likely to conceal fish</li> <li>high flow: upstream</li> <li>low flow: not necessary to match boat movement to water flow, and the boat can be controlled by ropes from the bank side if required</li> </ul>
9. Movement	slowly, covering the habitat with a sweeping movement of the anodes and attempt to draw fish out of hiding	slowly, covering the habitat with a sweeping movement of the anodes or drifting with the boom along selected habitats and attempting to draw fish out of hiding
10. Stop nets	used if necessary and feasible	used if necessary and feasible
Field-photo example	 River depth < 0.7 m (photo S. Schmutz)	 River depth > 0.7 m (photo Z. Kaczowski)



#### STEP 4. Collecting fish data

To calculate the EFI, each sampled fish should be identified to species level by external morphological features and the total number of specimens per species should be recorded on the field protocol data sheet (**Table 7** see **Annex**).

#### STEP 5. Input of data into EFI database

To start the data processing prepared input files: **inputfile\_eft** and **inputfile\_efi** should be download from <http://fame.boku.ac.at>.

##### 5.1. Worksheet\_inputfile\_eft

To calculate the European Fish Type (EFT) for selected site, the field data from Annex 1 and the data collected from Table 2 should be insert to inputfile\_eft.

##### 5.2. Worksheet\_inputfile\_efi

To calculate the European Fish Index (EFI) for selected site, the field data from Annex 1, Annex 2 and the data collected for Table 2 should be insert to inputfile\_efi.

#### STEP 6. Assessment of site with the EFI software

EFI software (after registration) and FAME CONSORTIUM – Manual for method description and software installation, should be downloaded from <http://fame.boku.ac.at>.

##### 6.1. Import of data to software

To calculate the European Fish Type (EFT) for selected site, the completed inputfile\_eft should be imported to EFI software. To calculate the European Fish Index (EFI) for selected site, the completed inputfile\_eft should be imported to EFI software.

##### 6.2. Run the software

Calculate **EFT** and than **EFI** for each site.

##### 6.3. Output

##### 6.3.1. Identification of European Fish Type (EFT)

To support the type specific approach of WFD the identification of European Fish Type (EFT) of selected site is integrated in the EFI application tools (software and manual). On the basis of dominant fish species the 15 European Fish types are determined to which the assessing sites may belong (**Table 5**).

##### 6.3.2. Calculation of observed, theoretical and probability metrics for EFI

Results of observed metrics are automatically written in the worksheet '*result*' and use for latter calculation in next worksheet '*metrics*' where the theoretical metrics, probability metrics and EFI index values are calculated and presented according to the 5-tiered scheme formulated in the WFD (see Figure 1).

##### 6.3.3. Calculation of EFI score and assignment to status class.

The final EFI for a site is obtaining by summing up and transforminng an achieved value towards the *Ecological Quality Ratio (EQR)* ranging from 0 to 1. The EQR scores the highest quality sites higher than 0.669 and the lowest quality sites below 0.187 (see Figure 2.7.).

#### 3. Results and discussion

Results should be prepared in form presented in **Table 8**, and discussed. The main questions to be answered and discussed are:

1. Does the EFI index show the ecological quality status of the given site that might be expected from the hydro-geomorphological conditions and fish fauna community sampled at this site?
2. Does the EFI index clearly separate the good, moderate and bad ecological quality status sites?
3. To what European Fish Types (EFT) belong investigated sites?

#### REFERENCES

1. CEN document. 2003. Water quality – Sampling of fish with electricity. CEN/TC 230, Ref. No. EN 14011:2003 E. 16 pp.
2. de Leeuw J.J., Buijse A. D., Haidvogel G., Lapinska M., Noble R., Repecka R., Virbickas T., Wiśniewolski W., Wolter C. 2007. Challenges in developing fish-based ecological assessment methods for large floodplain rivers. *Fisheries Management and Ecology* 14(6):483-494.
3. FAME CONSORTIUM. 2004. Manual for the application of the European Fish Index – EFI. A fish-based method to assess the ecological status of European rivers in support of the Water Framework Directive. Version 1.1., January 2005. 92 pp. (to download from <http://fame.boku.ac.at>).
4. <http://fame.boku.ac.at>. 2001-2004. Development, Evaluation and Implementation of a

- Standardized Fish-based Assessment Method for the Ecological Status of European Rivers (A Contribution to the Water Framework Directive) - contract no.: EVK1-CT-2001-00094. Grant of European Union, Key Action 1: Sustainable Management and Quality of Water (1.2.1. Ecosystem functioning, 1.7. Pre-normative, co-normative research and standardization); coordinator: Stefan Schmutz, University of Natural Resources and Applied Life Sciences, Vienna, Austria; number of countries involved: 12. Project acronym: FAME. Project website.
5. Karr J.R. 1981. Assessment of biotic integrity using fish communities. *Fisheries* 6:21-27.
  6. Lapinska M., Kaczkowski Z., Zalewski M. 2002. Restoration of streams for water quality improvement and fishery enhancement. *In: M. Zalewski (ed.) Guidelines for the Integrated Management of the Watershed – Phytotechnology and Ecohydrology.* 113-125 pp. United Nations Environment Programme, Division of Technology, Industry and Economics. Freshwater Management, Series No.5. 188 pp.
  7. Lapinska M., Zalewski M., Trojanowska A. 2004a. *Chapter 6: STREAMS & RIVERS: Defining their Quality & Absorbing Capacity.* Pp. 75-90. *In: M. Zalewski, I. Wagner-Łotkowska (eds) Integrated Watershed Management - Ecohydrology and Phytotechnology. Manual. UNESCO Regional Bureau for Science in Europe ROSTE.* 246 pp. (<http://www.unep.or.jp/ietc/Publications/Freshwater/watershedmanual>)
  8. Lapinska M., Krauze K., Kaczkowski Z. 2004b. *Chapter 11: MANAGEMENT OF STREAMS & RIVERS: How to Enhance Absorbing Capacity against Human Impacts.* pp. 169-184. *In: M. Zalewski, Wagner-Łotkowska I. (eds) Integrated Watershed Management - Ecohydrology and Phytotechnology. Manual. UNESCO Regional Bureau for Science in Europe ROSTE.* 246 pp. (<http://www.unep.or.jp/ietc/Publications/Freshwater/watershedmanual>).
  9. WFD EU, Water Framework Directive. 2000. Directive of the European parliament and of the council 2000/60/EC establishing a framework for community action in the field of water policy. Official Journal of the European Communities 22.12.2000 L 327/1.
  10. Winter H.V., Lapinska M., de Leeuw J.J. 2007. The river Vecht fish community after rehabilitation measures: a comparison to the historical situation by using the river Biebrza as a geographical reference. *River Research and Applications.* Published online in Wiley InterScience. ([www.interscience.wiley.com](http://www.interscience.wiley.com)) DOI: 10.1002/rra.1081
  11. Verdonschot P.F.M., Lapinska M., Zalewski M. 2006. RIVER ECOSYSTEMS REHABILITATION. *In: Fresh Surface Water, J.C.I. Dooge (ed.) Encyclopedia of Life Support Systems (EOLSS).* Developed under the Auspices of the UNESCO, Eolss Publishers, Oxford ,UK. [Retrieved January 4, 2007]. (<http://www.eolss.net>)
  12. Zalewski M. 2000. Ecohydrology - the scientific background to use ecosystem properties as management tools toward sustainability of water resources. Guest Editorial in *Ecological Engineering* 16:1–8.
  13. Zalewski M. (ed.). 2002. Guidelines for the Integrated Management of the Watershed - Phytotechnology and Ecohydrology. United Nations Environment Programme, Division of Technology, Industry and Economics. International Environmental Technology Centre. Freshwater Management Series no. 5. 188 pp. (<http://www.unep.or.jp/ietc/Publications/Freshwater/FMS5/>).
  14. Zalewski M., Wagner-Łotkowska I. (eds) 2004. *Integrated Watershed Management - Ecohydrology and Phytotechnology. Manual. UNESCO Regional Bureau for Science in Europe ROSTE.* 246 pp. (<http://www.unep.or.jp/ietc/Publications/Freshwater/watershedmanual>).

## ANNEX

**Table 6.** *Basic abiotic and method data (see Table 2) field protocol.*

Date (dd/mm/yyyy)	
<b>Site data</b>	
River name	
XY co-ordinates	
longitude, latitude	
Site name	
Site code	
GPS co-ordinates	
<b>Abiotic variables</b>	
Altitude	m
Lakes upstream affecting the site	Yes / No
Distance from source	km
Flow regime	Permanent / Summer dry
Wetted width	m
Geological typology	Siliceous / Calcareous
Mean air temperature	Celsius (°C)
Slope	(‰)
Size of catchment class	Classes: <10, <100, <1000, <10000, >10000 km <sup>2</sup>
<b>Variables describing sampling methods</b>	
Method	Electrofishing: Wading / by Boat
Sampling strategy	Whole / Partial 1 bank / Partial 2 banks / Partial random / Partial proportional / Other (define)
Fished area	m <sup>2</sup>
<b>Site photo</b>	

**Table 7.** *Fish data field protocol.*

<b>Date</b> (dd/mm/yyyy)			
<b>Site data</b>			
River name		Site code	
XY co-ordinates		Main river region	
longitude, latitude		GPS co-ordinates	
Site name		Transect length (m)	
<b>Fish data</b>			
	Species name	Number of specimen	
1		31	
2		32	
3		33	
4		34	
5		35	
6		36	
7		37	
8		38	
9		39	
10		40	
11		41	
12		42	
13		43	
14		44	
15		45	
16		46	
17		47	
18		48	
19		39	
20		50	
21		51	
22		52	
23		53	
24		54	
25		55	
26		56	
27		57	
28		58	
29		59	
30		60	

**Table 8.** *Result of EFI index application – scheme.*

<b>Rivername:</b>	
<b>Sitename:</b>	
<b>Sitecode:</b>	
<b>Sampling date:</b>	
<b>European Fish Type (EFT):</b>	
<b>Abiotic variables</b> (see Table 2)	
Geology	
Size of catchment [km <sup>2</sup> ]	
Altitude [m]	
Flow regime	
Upstream lakes influenced site	
Mean air temperature [°C]	
Slope [‰]	
Distance from source [km]	
Wetted width [m]	
Sampling strategy	
Sampling method	
Fished area [m <sup>2</sup> ]	
Main river region / river group	
Ecoregion [see Annex 2-Table 2, p.62 in FAME CONSORTIUM-Manual 2004]	
Conductivity [mS/m]	
<b>Site photo</b>	
<b>Fish data</b>	
Species	Number of fish caught
1.	
2.	
etc.	
<b>European Fish Index score:</b>	
<b>Ecological status class:</b>	class
	colour

## 17. ARE MALES SPECIMENS MORE ADEQUATE TO DETECT ANTROPOGENIC IMPACTS?

### Chapter Objectives

To demonstrate sex effects on different aquatic species condition and its susceptibility to anthropogenic impacts.



Field sampling (photo Ecoreach)

**EH principle: 1 – use of biota as impact indicators**

### INTRODUCTION

Estimates of the condition of aquatic organisms can be used to monitor the health or recovery of aquatic areas, under the ecohydrologic approach (Zalewski 2000, Chicharo *et al.* 2001). The ability of aquatic organisms to cope with environmental stress may be expensive in terms of energy and this cost of tolerance have negative counterparts in growth, reproduction, recruitment, susceptibility to disease, predation and physical disturbance (Jackson *et al.* 2002, Lloret *et al.* 2003, Oliva-Paterna *et al.* 2003). Density-dependent factors such competition and aggression can influence fitness, growth, reproduction, and survival (Hensor *et al.* 2005, Leitão 2006). **Indices of the condition of organisms are valuable for managers of aquatic ecosystems for assessment of the health status of populations (Brown, Austin 1996).**

### ELABORATING OF THE EXPERIMENT

#### 1. General description

The relationship between the condition of adults during the months prior to spawning and the number of recruits in the following year was been significant and positive for some aquatic species (Carbonell *et al.* in press). This relationship was stronger when only male condition was considered, suggesting that males must be considered differently (Carbonell *et al.* in press). Also Chicharo *et al.* (2007) showed that the males of three different marine species are more susceptible to environmental changes. Nevertheless, there is a paucity of data on the effects of sex on growth, energetics, and condition of aquatic organisms. Several studies of the growth rates and conditions of aquatic organisms assumed no differences between

males and females in the condition based on morphometric (Gerritsen, McGrath 2007) and on biochemical content of muscle tissue or of the whole organism eg.:Regnault and Luquet (1974), Paon and Kenchington (1995), Chicharo *et al.* (2003), and Norkko *et al.* (2005).

There are several methods to determine aquatic organisms condition, some of the most generalized are: the morphometric condition index (Nash *et al.* 2007), an indicator of the general well-being, this index assumes that heavier organism for a given length are in better condition, and the RNA/DNA ratio, this index is based on the assumption that the amount of deoxyribonucleic acid DNA, the primary carrier of genetic information, is stable under changing environmental situations, whereas the amount of ribosomal ribonucleic acid RNA is directly involved in protein synthesis, is affected by environmental changes (Bulow 1970).

**The aim of this work is to quantify differences between male and female condition of fish and aquatic invertebrate's species, using biometric biochemical analysis.**

#### 2. Experimental design

It should be selected species with different habitats and feeding habits to negate the confounding effect of physiological, morphometric, and behavioural changes on differences in condition indices, between males and females. It can be suggested species with wide distribution such as gobiid fishes (eg *Pomatoschistus* spp), crustaceans (eg *Crangon* spp., *Carcinus maenas*), and bivalves (eg *Cardium* spp)

The alive adult organisms can be sampled (eg fish and shrimp, in rocky or mud ponds) or buy in local market (eg bivalves). All the specimens should be submitting to cumulative stress

conditions in aquaria during 3-4 days, eg hypoxia or starvation. Organisms will be frozen or preferably placed in liquid nitrogen immediately after collection.

### a) Laboratory analysis

Fish, shrimp and bivalve specimens will be observed, after defrost, using a dissecting microscope sex identified, total length measure, wet and dry weight determined. For all organisms macro structure maturation staged should be registered.

Condition factor will be determined based on formula  $K = W/L^3$ , where  $W$  is the body mass (mg) and  $L$  is the standard length (mm).

RNA and DNA contents can be analyzed according to fluorometric methods described by Esteves *et al.* (2000). Nucleic acids are extracted from a portion of 200  $\mu\text{g}$  tissue in white muscle samples by adding 150  $\mu\text{l}$  of 1% sarcosine and crushing the samples in ice (**Figure 1**).

After shaking and centrifugating, the samples are diluted to a final concentration of 0.1% using ice-cold Tris buffer. Fluorescence are measured photometrically using ethidium bromide. The amount of fluorescence originating from RNA (mainly ribosomal RNA) are calculated as the difference between total fluorescence (RNA and DNA) and fluorescence after ribonuclease A (type II-A) treatment, which are assumed to be derived from DNA. Fluorescence are determined by excitation at 365 nm and detection at 590 nm using spectrofluorometer (**Photo 1**). Sample concentrations of nucleic acids will be determined from standard curves constructed daily using lambda DNA and ribosomal RNA of known concentration and of the appropriate range.

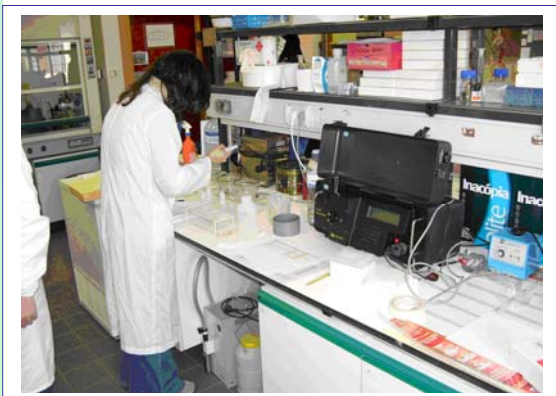

**Photo 1.** Fluorescence determination with use of spectrofluorometer.

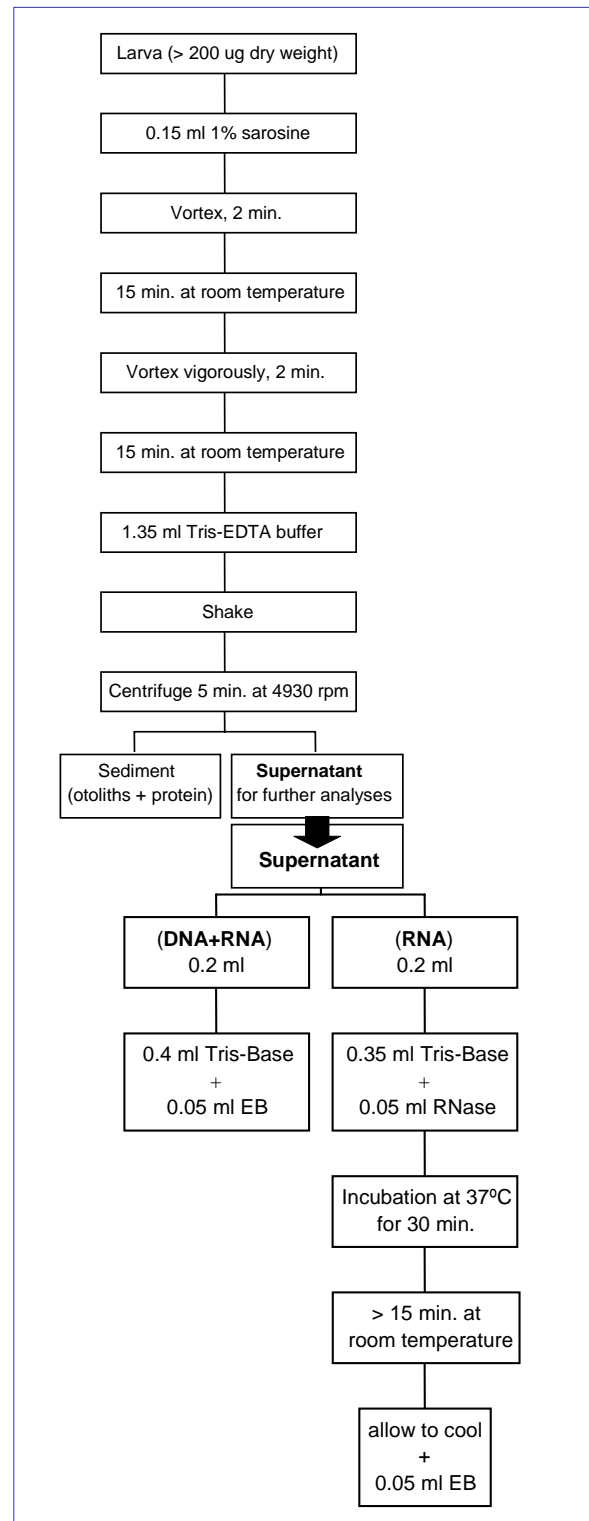

**Figure 1.** Flow-chart of sarcosine extraction procedure and quantification methodology of nucleic acids described by Esteves *et al.* (2000).

### 3. Materials and equipment

#### a) Field collection

You will need materials and equipment to collect water, fish, shrimps and bivalves:

- Baskets and containers for water collection and transport to the lab;
- Small hand-dredge for bivalve, crustacean and fish sampling in ponds;
- Clothing: water proof boots to walk on the margins, water proof jacket.

#### b) Laboratory experiments

- Calliper;
- Dissecting microscope and microscope;
- Owen and muffle for determination of organisms AFDW (ash free dry weight);
- Fluorometer;
- Centrifuge;
- Water bath;
- Automatic pipettes.

#### c) Data analysis

- Computer;
- Data sheet organizer.

### 4. Organizing the data

#### Basic statistical analysis

It will be necessary for morphometric condition index to organize the data according to the example in **Table 1**.

**Table 1.** *Morphometric index determined in Carcinus maenas*

Wet weight (mg)	Total length (mm)	Sex	Weight/Length <sup>3</sup>
2120	16,72	Female	0,45
3580	19,37	Female	0,49
4050	19,48	Female	0,55
4510	20,84	Female	0,50
5780	22,38	Female	0,52
6050	24,93	Female	0,39
6570	23,52	Female	0,50
6880	23,97	Female	0,50
7350	25,72	Female	0,43
3630	19,86	Male	0,46
3650	19,87	Male	0,47
6020	23,63	Male	0,46
8700	26,27	Male	0,48
10450	29,4	Male	0,41
11990	28,36	Male	0,53
13600	31,03	Male	0,46
17700	31,72	Male	0,55

It will be necessary to perform a regression analysis between fluorescence units and acids nucleic concentrations (see **Figure 2**).

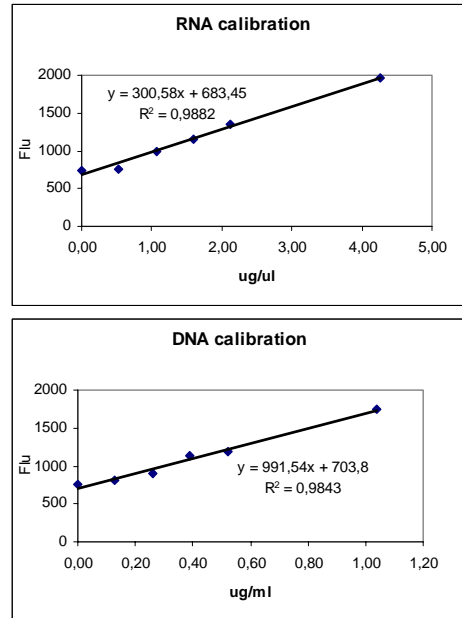

**Figure 2.** *Relationship between standard nucleic acids concentration and relative fluorescence readings.*

To analyse sex differences in condition indices it will be necessary to perform T- student test ( $p < 0,05$ ), see examples of results in **Table 2** and **Figure 3** and **Figure 4**.

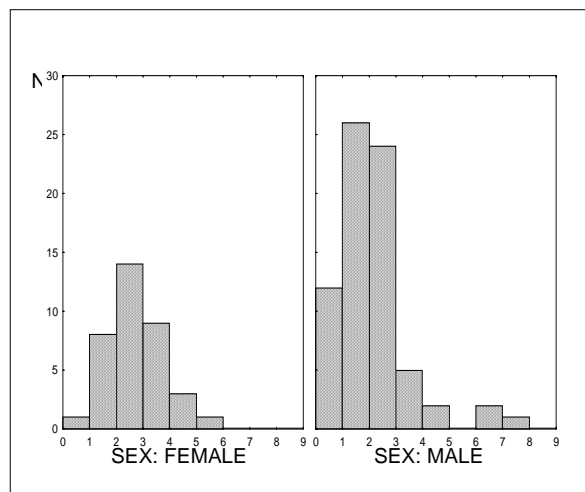

**Figure 3.** *Results of RNA/DNA ratios between males and females goby fish (Chicharo et al. 2007).*

**Table 2.** Total length (mm), Dry weight( g) (for bivalves only meat weight and nucleic acid index of three species (mean ± standard deviation) and P values for differences between males and females of each species (P ♂♀) (Chicharo et al. 2007).

Species	n	LENGTH	P	DRY WEIGHT	P	RNA/DNA	P
<i>Pomatoschistus microps</i>	126	45.41 ± 8.28	0.052	0.086±0.174	0.004	2.25 ± 1.27	0.006
Female	42	43.38 ± 8.96		0.086±0.141		2.68 ± 1.05	
Male	84	45.41 ± 7,78		0.081±0.19		2.03 ± 1.33	
<i>Crangon crangon</i>	155	29.25 ± 8.1	0.037	0.037±0.013	0.01	8.06 ± 5.55	0.156
Female	135	29.75 ± 8.21		0.044±0.014		8.3 ± 5.65	
Male	18	25.56 ± 4.71		0.035±0.012		6.28 ± 4.66	
<i>Ruditapes decussates</i>	38	33.4 ± 1,33	0.485	0.286±0.019	0.85	0.24 ± 0.257	0.009
Female	18	33.24 ± 1.51		0.285±0.012		0.33 ± 0.258	
Male	20	33.55 ± 1.16		0.29±0.01		0.16 ± 0.092	

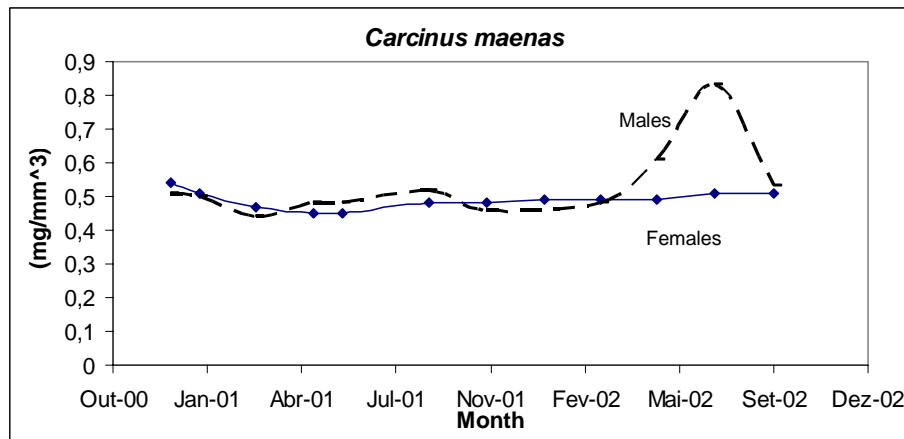

**Figure 4.** *Carcinus maenas* variation of morphometric condition index between genders along different seasons.

**6. Analysing the results**

To analyse the results try to have in consideration that your data may have been caused by sexual dimorphism, physiological or biochemical differences between sexes, or behavioral differences between sexes. Try to give especially attention to the investment of reproduction between the sexes of species analysed (Brokordt et al. 2003).

During the analysis try to answer to the following questions:

1. Which index is more sensitive to anthropogenic impact?
2. How did these ratios vary with the sex of the organism in different species?
3. Are males specimens more adequate to detected anthropogenic impacts?
4. If the frequencies of genders in samples are not representative of those in the population, what can happen to the analysis of population condition, eg. if females are over-represented?

## 7. Discussion

Discuss the obtained results with literature concerning the topic.

## REFERENCES

1. Brokordt K.B., Guderley H.E., Guay M., Gaymer C.F., Himmelman J.H. 2003. Sex differences in reproductive investment: maternal care reduces escape response capacity in the whelk *Buccinum undatum*. *Journal of Experimental Marine Biology and Ecology* 291:161–180.
2. Brown M.L., Austin D.J. 1996. Data management and statistical techniques. *In*: B.R. Murphy, D.W. Willis (eds). *Fisheries Techniques*. American Fisheries Society, Bethesda, Maryland. 17–61 pp.
3. Bulow F.J. 1970. RNA–DNA ratios as indicators of recent growth rates of a fish. *Journal of The Fisheries Research Board of Canada* 27:2343–2349.
4. Carbonell A., Lloret J. Demestre M. (*in press*). Relationship between condition and recruitment success of red shrimp (*Aristeus antennatus*) in the Balearic Sea (Northwestern Mediterranean). *Journal of Marine Systems* 0:000-000.
5. Chícharo M. A., Chícharo L., Galvão H., Barbosa A., Marques M. H., Andrade J. P., Esteves E., Miguel C., Gouveia C., Rocha C. 2001. Status of the Guadiana estuary (South Portugal) during 1996-1998: an ecohydrological approach. *Aquatic Ecosystem Health and Management* 4:73-90.
6. Chícharo M. A., Chícharo L., Morais P. 2007. Sex effect on ratios and concentrations of DNA and RNA three in marine organisms. *Marine Ecology Progress Series* 332:241-245.
7. Chícharo M.A., Chícharo L., Amaral A., Condinho S., Gaspar M. 2003. Chronic effects of dredging-induced stress on the clam (*Spisula solida*): nucleic acid and lipid composition. *Fisheries Research* 63:447–452.
8. Esteves E., Chícharo M.A., Pina T., Coelho M.L., Andrade J.P. 2000. Comparison of RNA/DNA ratios obtained with two methods for nucleic acid quantification in gobiid larvae. *Journal of Experimental Marine Biology and Ecology* 245:43–55.
9. Gerritsen H.D., McGrath D. 2007. Significant differences in the length–weight relationships of neighbouring stocks can result in biased biomass estimates: Examples of haddock (*Melanogrammus aeglefinus*, L.) and whiting (*Merlangius merlangus*, L.). *Fisheries Research* 85(1-2):106-111.
10. Hensor E., Couzin I.D., James R., Krause J. 2005. Modelling density-dependent fish shoal distributions in the laboratory and field. *Oikos* 110:344–352.
11. Jackson A.C., Rundle S.D., Attrill M.J. 2002. Fitness consequences of prey depletion for the common goby *Pomatoschistus microps*. *Mar Ecol Progress Series* 242:229–235.
12. Leitão R., Martinho F., Neto J.M., Cabral H., Marques J., Pardal M.A. 2006. Feeding ecology, population structure and distribution of *Pomatoschistus microps* (Krøyer, 1838) and *Pomatoschistus minutus* (Pallas, 1770) in a temperate estuary, Portugal. *Estuarine Coastal Shelfish Science* 66:231–239.
13. Lloret J., Planes S. 2003. Condition, feeding and reproductive potential of white seabream *Diplodus sargus* as indicators of habitat quality and the effect of reserve protection in the northwestern Mediterranean. *Marine Ecology Progress Series* 248:197–208.
14. Nash R. D. M., Valencia A.H., Geffen A.J. 2006. Essay: Fisheries History. The Origin of Fulton's Condition Factor - Setting the Record Straight. *Fisheries* 31(5):236-238.
15. Norkko J., Pilditch C.A., Thrush S.F., Wells R.M.G. 2005. Effects of food availability hypoxia on bivalves: the value of using multiple parameters to measure bivalve condition in environmental studies. *Marine Ecology Progress Series* 298:205–218.
16. Oliva-Paterna F.J., Vila-Gisbert A., Torralva M. 2003. Condition of *Barbus sclateri* from semiarid aquatic systems: effects of habitat quality disturbances. *Journal of Fish Biology* 63:1–11.
17. Paon L.A., Kenchington E.L.R. 1995. Changes in somatic and reproductive tissues during artificial conditioning of the sea scallop, *Placopecten magellanicus* (Gmelin, 1791). *Journal of Shellfish Research* 14:53–58.
18. Regnault M., Luquet P. 1974. Study by evolution of nucleic acid content of prepubertal growth in the shrimp *Crangon vulgaris*. *Marine Biology* 25:291–298.
19. Zalewski M. 2000. Ecohydrology-the scientific background to use ecosystem properties as management tools toward sustainability of water resources. *Guest Editorial in Ecological Engineering* 16:1-8.



## 18. HOW DO WETLAND VEGETATION CHARACTERISTICS DEPEND ON HYDROLOGY, TOPOGRAPHY AND SUBSTRATE BIOGEOCHEMISTRY?

### Chapter Objectives

To quantify and understand how inundation dynamics determines key soil and vegetation properties in coastal wetlands and how this is related to phosphorus trapping.



*Wetlands of Guadiana estuary, Portugal  
(photo David Piló)*

**EH principle: 1 – quantifications of processes**

### INTRODUCTION

Vegetation biomass in coastal wetlands is to a large extent dependent on the salt tolerance of the different plant species and on the nutrient availability of the sediments or soil on which the plants grow. The concentration and distribution of porewater salts, pH and the amount of phosphorus in the substrate are highly dependent on the flooding frequency. The latter depends on the tidal and estuarine dynamics in combination with the basin topography. The capacity of local plant species to capture phosphorus from the environment under different environmental settings will be evaluated. **The practical experiments presented here stress the quantification of these factors and their interpretation under an integrated ecohydrological approach (Zalewski 2000).**

### ELABORATING THE EXPERIMENT

#### 1. General description

The topography of an intertidal wetland will be determined considering the maximal tidal elevation along a transect cutting through an ecotone or a clear vegetation transition. In this transect, main vegetation features such as composition, density, height and tree diameter in breast height (dbh) will be recorded. Sediment samples will be taken for the determination of porewater salinity, pH and total phosphorus. Leaf samples from the relevant species will be taken for total P determination.

#### 2. Experimental design

The experiment design involves a transect including 12 stations distributed along an evident vegetation gradient. In case vegetation composition is homogeneous, other features that systematically vary along a topographically relevant axis should be considered, such as e.g. vegetation height or density. The stations will not be randomly distributed, but following the distribution of geobotanical properties. The transect should be approximately perpendicular to topographic isolines, i.e. cutting through the inundation front.

Before the establishment of the sampling stations, topography will be determined by establishing a network of approximately 50 nodes where simple, self-constructed devices for measuring maximum tidal elevation will be installed (see **Figure 1**). The position of each node will be determined by GPS, but also measuring the distances to an origin of coordinates previously established at a point easily recognizable, e.g. in a map or a satellite image. The purpose of this will also be to familiarize the students with the precision of satellite positioning systems as compared with high-resolution field measurements. Further, in a more advanced stage this will allow the quantification of eventual ecotone shifts or other environmental changes such as e.g. erosion or sediment deposition.

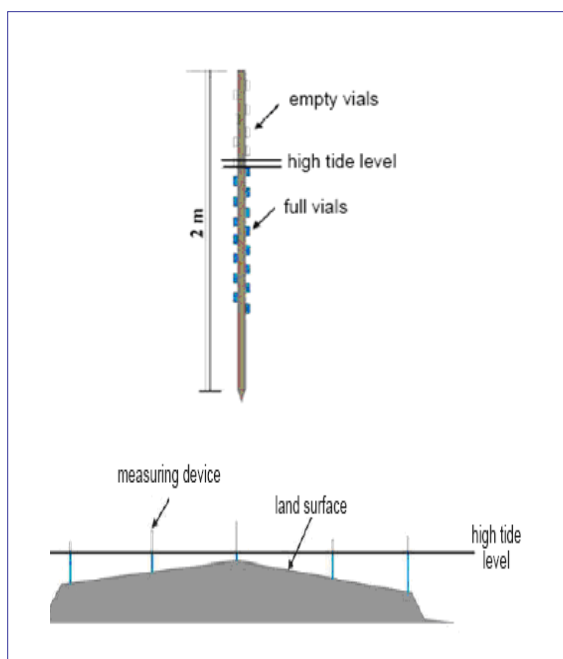

**Figure 1.** *Determination of wetland topography.*

The tidal elevation data from each node will be used together with its coordinates to elaborate a contour plot for the establishment of the above mentioned transect. Around each station, four sampling points will be established for assessing internal variability. Tidal elevations can be converted in topography data relating them to local mean sea level values (Cohen, Lara 2003, Cohen *et al.* 2004).

### 3. Materials and equipment

#### a) Field work

- vials, plastic bags and simple equipment to collect surface sediments and plant material (e.g. clean metal spoons and scissors);
- GPS instrument for positioning;
- measuring tape (20 m) for determining distances between topography nodes;
- conductimeter to measure in-situ salinity of neighboring water bodies;
- pH meter with a SensoLyt SE (WTW GmbH & Co. KG, 193Weilheim, Germany) electrode or similar, suitable for pH measurement in slurries;
- clothing: waterproof boots to walk on the margins, waterproof jacket;
- Wood or bamboo sticks, 10-20 ml plastic vials (such as scintillation vials) and waterproof

tape for constructing the devices as in Figure 1.

#### b) Laboratory work

General needs:

You will need a wet lab, where “dirty” material such as mud samples can be processed. On the other side, you will have to keep a part of the lab strictly clean for the chemical analysis, or do this in a separate lab.

Specific laboratory equipment:

- drying oven
- balance (analytical and semi-analytical)
- spectrophotometer
- glassware
- reagents for phosphorus determination (see references)
- furnace
- sieves
- conductimeter for salinity determination

#### c) Data analysis

- computer;
- data sheet organizer;
- software allowing 3D graphics with interpolation algorithms;
- printer.

#### d) Safety information

*Check the weather forecast before going to the field. Use appropriate clothing. Do not walk into deeper water or enter a boat wearing your waterproof boots. Beware of touching electric devices with wet hands. Be very careful when using all electric equipments.*

### 4. Experiment description

After sample collection, plant material will be classified into species and within each species in roots, stem and leaves, rinsed with tap water to eliminate mud and then with distilled water. Handle all plant material with pincettes and latex gloves. It will be then air dried overnight on clean paper sheets. Next day, it will be put into paper bags and dried at 60°C to constant weight. Write on each bag the type of material and dry weight. This material will be ground and aliquots weighted for phosphorus determination.

**Sediment samples** will be collected in triplicate with a metal spoon from a depth of 10-20 cm depth, depending on the distribution of root biomass, after removing surface layers and detritus. Sediments will be homogenized with a

glass rod and divided into several aliquots for the different analysis. Preparation of the samples include careful removal of visible roots, drying at 60°C and grinding to <300 µm mesh.

Water (250 ml) from the surrounding water bodies will be collected and vacuum-filtered through Whatman GF/C or GF/F filters,

The sediment pH is measured in the field inserting the electrode directly into the sediment at sampling depth and waiting until stable values are reached. Porewater salinity is measured in the lab by conductivity/salinity measurement in the clear supernatant of 1:5 weight:volumen sediment:water slurries, after stirring and allowing the sediment to settle overnight. Conversion of slurry- to porewater salinities will be performed using the formula in the annex. Grain size (silt/clay content) will be determined by wet sieving. Sediment water content will be determined by difference of the weights before and after drying at 105°C. Aliquots for chemical analysis will be dried, ground and weighted.

Detailed sampling and sample processing involves the following steps. At each station, one composite leaf sample (n= 20) will be collected from a tree or bush closest to the location where the sediment sample is taken and another pooled leaf sample (n=60) will be taken from three more plants around this position. The leaves will be divided into subsamples by separating them into three size classes by their width: <2.5 cm (class 1), 2.5-4.0 cm (class 2) and > 4.0 cm (class 3). Leaves will be cleaned with deionised water and tissue paper in order to remove attached salts and other particles. Leaf petioles will be removed and the leaves dried to constant weight at 60°C, then ground to <80 µm mesh. The powder must be kept in a dessicator until analysis.

**To determine total P** content in leaves (all three size classes separately and sediments), 50 mg of each sample will be weighed in crucibles and combusted in a furnace at 810°C for two hours. After cooling, 10 ml of HNO<sub>3</sub> (20%) is carefully added to the samples. The crucibles will be reheated on a sand bath until the liquid begins to boil. After cooling, the suspensions are quantitatively filtered into 100 ml volumetric flasks, rinsing crucibles and filters thoroughly with deionised water, and filling the flasks up to exactly 100 ml.

Phosphate concentration in the filtrates from sediment and leaves hydrolisates as well as from water samples will be determined spectrophotometrically after [Murphy and Riley \(1962\)](#). Environmental concentrations are back calculated to mg of P per g of sediment or leave sample or per liter in the case of the water samples. As exercise, P amounts should be also expressed on molar basis.

The phosphorus accumulation coefficient will be calculated relating P concentrations in sediment and leaves using the formula in the annex.

## 5. Organising the data

### Data calculation

1. Construct a data sheet.
2. Transform water height determined in field work into elevation above sea-level referring elevation data to tidal height (see References)
3. Calculate inundation frequency from topography (elevation) and tidal regime (frequency distribution of maximum tidal elevation).

### Analyses

1. Analysis of variability within replicates.
2. Carry out regression and correlation analysis between chemical analysis of sediments and plant material and porewater salinity, pH and inundation frequency and topographic elevations.

### Statistical tests

1. T-Student.
2. Regression, correlation.

### Making graphs

1. Testing graphical representation of the results
2. Draw contour plots and 3-D representation of wetland topography.
3. Situate vegetation units into the elevation contour plots.

## 6. Analysing the results

1. Evaluate in what range of salinities or inundation frequencies range plants contain more phosphorus as compared to phosphorus content in the sediment.
2. Filter the above mentioned e.g. salinity effect, and evaluate whether there are significant trends.

3. Are there significant intraspecific differences regarding plant phosphorus contents at each station?
4. How did the P contents of plant material vary with a biomass estimator such as e.g. plant height or dbh?

## 7. Discussion

1. Which plant species seem more adequate for extracting phosphorus from polluted waters?
2. Considering the topographical habitat these plants occupy, how would you manage the investigated wetland for maximizing phosphorus sequestration?
3. If you have to do this experiment again, what would you change? Justify your answer.

## REFERENCES

1. Cohen M.C.L., Lara R.J. 2003. Temporal changes of mangroves vegetation boundaries in Amazonia: application of GIS and remote sensing techniques. *Wetlands Ecology and Management* 11(4):223-231.
2. Cohen M., Lara R.J., Szlafsztein C.F., Dittmar T. 2004. Mangrove inundation and nutrient dynamics under a GIS perspective. *Wetlands Ecology and Management* 12:81-86.
3. Murphy J., Riley J.P. 1962. A modified single solution method for the determination of phosphate in natural waters. *Analytica Chimica Acta* 27:31-36.
4. Zalewski M. 2000. Ecohydrology-the scientific background to use ecosystem properties as management tools toward sustainability of water resources. Guest Editorial in *Ecological Engineering* 16:1-8.

## ANNEX

### Formulas:

1. Calculation of porewater salinity ( $K_e$  ‰)

$$K_g [\text{‰}] = K_g (V_p + V_s) / V_p$$

Legend:

$K_g$  [‰] - salinity of 1:5 extract

$V_p$  [mL] - volume of water in fresh sample calculated out of %humidity and fresh weight of sample

$V_s$  [mL] - volume of water which is added to fresh sample

$K_e$  [‰] - calculated/true salinity of extract

2. Phosphorus accumulation coefficient ( $P_{AC}$ ).

$P_{AC}$  in vegetation,  $P_{ACV} = P_L / P_S$

$P_L = P$  in leaves or other vegetation parts

$P_S = P$  in sediments near the roots

$P_{AC}$  in sediment,  $P_{ACS} = P_S / P_W$

$P_S = P$  in sediments near roots and in vegetation free areas (compare)

$P_W = P$  in water flooding the station or in nearby creek

## 19. MAY WATERSHED LAND COVER BE USED AS AN INDICATOR OF POTENTIAL ANTHROPOGENIC IMPACT ON WATER RESOURCES?

### Chapter Objectives

To demonstrate how to use information on human activities in the watershed for water resources management.



Vistula River watershed, Poland (photo ERCE)

**EH principle: 1 – use of biota as impact indicators**

### INTRODUCTON

Water availability and water quality is a function of human activities in the watershed. Increasing urbanization, intensive agricultural practices and industrialization are some of the factors contributing to water quality degradation and biodiversity loss. Any solution to water management must be based on a deep knowledge of ecosystem processes and functioning at a watershed scale including terrestrial and aquatic environments.

In order to implement an integrated watershed management it is necessary to identify most natural or less degraded watershed to be used as indicators of desired water conditions in a given area/region. Using remote sensing information and **Geographic Information Systems** it is possible to carry on a comparative analysis of sub-basins using land cover and other sources of information on human activities as indicators of anthropogenic impact. There are many indicators variables that can be used to analyze the impact of human activities on natural resources or environmental condition. Some of them synthesize the state or conditions of the watershed (state indicators) while others points towards human pressure on water resources (pressure indicators). Many of the variables used in this manual are designed to show or analyze existing water quality or condition (DO, pH, temperature, chlorophyll content, species biomass or diversity). In this chapter we will be using variables related to human activities in the watershed that synthesize human pressure on natural resources that might affect water quality. **It is important to point out that similar human pressure might affect differentially water quality depending on aquatic ecosystems properties (i.e.: ecosystem carrying capacity and resilience).**

**This experiment helps to show basic EH concepts: landscape ecological analysis of a watershed allows the understanding of ecosystem pattern and processes related to water availability and quality. Landscape planning for agricultural, urban or infrastructural development, must take into consideration land-water interactions at a regional scale (Zalewski 2000).**

### ELABORATING THE EXPERIMENT

#### 1. General description

The experiment proposed depicts a procedure for analyzing information obtained by remote sensing and other sources, and processed by **Geographic Information System (GIS)**. We will be using general software (i.e., Excel) and free GIS software (**QGIS**) for doing the calculation needed. The aim will be to compare the land cover and the intensity of activities in different areas (different sectors or subunits of a watershed belonging to a similar region or large basin) in order to identify those sectors more and less impacted by human activities based on land cover/uses. To do so, environmental indicators will be develop and applied to synthesize the information available for each area (sub-basins). This will allow us to elaborate a ranking of watershed based on the potential anthropogenic impact. The water features (parameters) of the less impacted watershed may then be used as standard parameters of **“natural water conditions”**.

First, we should define the study area and the units of analysis; then we should identify land use indicators and obtain this information for each unit. After the organization and standardization of the data, we will be able to

calculate synthetic indices that will allow us to carry on a spatial analysis.

## 2. Experimental Design

The procedure will be explained using an example based on the information attached to this guide.

### STEP 1. Define Study Area and Units of Analysis

The study area could be a large regional watershed comprised with several sub-basins or homogeneous areas that will be used as units of analysis. **Figure 1** shows a large watershed (Rio Salado, Buenos Aires, R. Argentina) to be used in our exercise. It has a surface of 1,000,000 ha., with more than 100 units of analysis (114 subbasins). The following procedure will allow us to elaborate a ranking of these units based on the degree of potential human impact using environmental indicators.

### STEP 2. Define land use indicators

Land use or activities indicators are variables related to human uses. There are many potential variables that can be selected as indicators of a given activity or land use, depending on information availability and accessibility. A description of its importance and some examples of indicators are given below (some of them will be used in our experience, see **Table 1** and **ejemplo.xls** in the "ejemplo1" folder attached in **Annex**).

**Agriculture, farming and forestry:** Major land cover change is due to an increase in the surface devoted towards crop production, cattle rising or forest plantations. They may increase water consumption (especially in irrigated areas) or water runoff (increasing soil erosion) modifying water dynamics and availability. Moreover, they can affect water quality because the intensive use of agrochemical products, such as fertilizers or pesticides might produce eutrophication (due to nitrogen or phosphorous increase) and/or contamination of waters downstream (due to an input of pesticide to the water body and to ecosystem trophic structure). Some potential indicators are:

- **Agricultural activity:** Proportion of land surface covered with crop (source: remote sensing analysis) or production of crops (source: regional statistical census) (see **Photo 1**);

- **Mixture of agriculture and farming system:** proportion of land surface covered with grasslands or crops (source: remote sensing analysis) or Cattle number/crop production (source: regional statistical census);
- **Farming activity:** proportion of land surface covered with grasslands (source: remote sensing analysis) or Cattle number/production (source: regional statistical census);
- **Forestry/permanent crops:** proportion of land surface covered with tree plantation or perennial crops (source: remote sensing analysis) or production of wood/crops (source: regional statistical census);



**Photo 1.** *Intensive agriculture (soybean field) can affect water quality (photo P. Pereyra).*

**Human population:** the amount of people and population growth rate are important indicators of direct human pressure on natural resources in a given area, both due to the demand of water (drinking, industrial, cleaning) or water contamination (sewage effluent). The intensity of human pressure depends on population number and its distribution in the area (rural/urban). Some potential indicators are:

- **Total population:** Total number of inhabitants in a given area/watershed (source: regional statistical census).
- **Rural population:** Number or proportion of total population living in rural areas (source: regional statistical census).
- **Urban population:** Number or proportion of total population living in urban areas (source: regional statistical census).

**Urban centers, industries and infrastructure:** man made ecosystems are those dominated by cities, roads, residential and industrial areas, transportation infrastructure, water channels and

reservoirs, etc.; where most of the natural processes have been affected (microclimatic condition, evaporation, runoff) or controlled. Some potential indicators are:

- **Urban centers:** total surface (hectares) or proportion of land covered with buildings and infrastructure (Remote sensing data);
- **Road Density:** Length of road system per surface area ( $\text{km}/\text{km}^2$ ; source: regional statistical census);
- **Industrial activity:** Number of industries in the area or some indirect estimation of industrial activity (such as percentage of regional or gross product due to industrial activity); (source: regional statistical census).



**Photo 2.** *Urban centers (populated city nearby natural areas) (photo R. Sarandón).*



**Photo 3.** *Infrastructure development can affect water dynamics (photo R. Sarandón).*

**Natural vegetation cover:** are indicators of natural ecosystem structure and processes

being maintained, which generally is an important watershed feature because perform a number of functions in watershed ecosystems such as an adequate groundwater recharge, maintenance of soil structure and properties, retain and process pollutants and nutrients, moderate extreme rainfalls events, protect wildlife habitat and biodiversity, etc. Some potential indicators are:

- **Natural Protected Areas:** Surface (hectares) or proportion of land covered or occupied by Natural Protected Areas (source: remote sensing analysis or regional statistical census);
- **Native Forest Cover:** Surface (hectares) or proportion of land covered or occupied by Native Forested (source: remote sensing analysis or regional statistical census);



**Photo 4.** *Natural grassland and managed vegetation in humid environments (photo R. Sarandón).*

**Water and wetlands:** aquatic ecosystems (lakes, lagoons) and wetlands are important elements in the functioning of watershed ecosystems: natural water reservoir, groundwater recharge, retain and process pollutants and nutrients, habitats for fish and wildlife, biodiversity conservation, recreational areas, etc. Some potential indicators are:

- **Wetlands and other water related areas:** Surface (hectares) or proportion of land covered with water, wetlands or related ecosystems (source: remote sensing analysis or regional statistical census);



**Photo 5.** *Natural reservoirs are important for water dynamic (photo R. Sarandón).*



**Photo 6.** *Wetlands surrounded by natural vegetation (photo R. Sarandón).*

For this experience the following set of indicators has been defined, the **Table 1** shows the variable code used the name of the indicator, units and source of information.

**Table 1.** *Set of indicators used in the experience.*

Nº	VarCod	Name	Units	Source
1	AGR	<b>Agricultural activity</b>	proportion	Remote sensing data
2	FAR	<b>Farming activity</b>	proportion	Remote sensing data
3	TPOP	<b>Total population</b>	numbers (x 1,000)	Census data
4	RDEN	<b>Road Density</b>	km/km <sup>2</sup>	Remote sensing data
5	IND	<b>Industrial activity</b>	numbers	Census data
6	NPA	<b>Natural Protected Areas</b>	proportion	Remote sensing data

### STEP 3. Data organization

The information obtained for each indicator must be organized as shown in the annexed Excel format file (**ejemplo.xls**; Raw Data), where each row corresponds to one of the 114 units of analysis (sub-watershed) and each column each of the 6 selected indicators.

All of them can be used as an estimation of human pressure on natural resources (for example by a simple sum of values for each units of analysis). Most of the indicators are positively correlated with human pressure, as a low value of AGR or TPOP correspond to a low human pressure, and higher values correspond to higher human pressure on natural resources. The exception is the NPA, for which a high value means a large portion of the area under some degree of protection. In order to allow the calculus of a synthetic value for each unit of analysis, NPA values must be transformed. It is simply done by calculating the proportion of the area NOT under a protection (1 minus NPA). This has already been done and incorporated in the last column of the Excel file (**ejemplo.xls** = NO-NPA, painted in green color, Raw Data).

### STEP 4. Data standardization

In order to express variables on the similar units to allow the calculus of a synthetic value, we have to transform the Raw Data to Standardized data (see the **ejemplo.xls** file: Raw data and Standardized Data, in the second page in the same Excel file). We have used the **equation 1**:

#### equation 1.

$$X_i = (R_i - R_{\min}) / (R_{\max} - R_{\min})$$

Where:

$R_i$  - variable value

$R_{\min}$  - minimum value

$R_{\max}$  - maximum value

*Example: 1<sup>th</sup> row of AGR indicator (second column)*

$$R_i = 0,090 \quad R_{\min} = 0,012 \quad R_{\max} = 0,420$$

$$X_i = (0,090 - 0,012) / (0,420 - 0,012) = 0.191$$

As a consequence of standardization all the indicators show a similar range of value (Min: 0,00; Max: 1,00), as you can see in the first row of Standardized Data matrix. In this matrix all the

indicators but IND have been standardized. You have to complete the standardized values for "IND" (Min: 0,00; Max: 45).

### STEP 5. Index calculation

In order to estimate a single value for each unit of analysis that synthesizes Potential Human Impact, we can calculate a Composed Index as the sum of the standardized value for each indicator. We can also divide the sum by the number of indicators ( $n = 6$ ) to obtain values between 0 and 1 (minimum and maximum human pressure respectively), using a general **equation 2**:

#### equation 2.

$$PHII = \sum w_i x_i$$

Where:

**PHII** - Potential Human Impact Index

**w<sub>i</sub>** - weight

**x<sub>i</sub>** - standardized variable value

*Example: (first row in ejemplo1.xls; Standardized Data matrix)*

$$(AGR + FAR + TOTPOP + RDENS + IND + NO-NPA) / 6 = PHI (SIM W)$$

$$(0.191 + 0.631 + 0.018 + 0.030 + 0.00 + 0.333) / 6 = 0,201$$

*Note: PHI (SIM W): Potential Human Impact (Similar weight) has been calculated in the 8th column of ejemplo1.xls for the first units of analysis*

In this case we have used a similar weight for all the indicators. We can write this in a different way to show this point (instead of dividing the sum by 6 we introduce a coefficient for each element in the sum ( $w_i = 1/6 = 0,167$ ):

$$0.191 \cdot 0.167 + 0.631 \cdot 0.167 + 0.018 \cdot 0.167 + 0.030 \cdot 0.167 + 0.00 \cdot 0.167 + 0.333 \cdot 0.167 = 0,201$$

If we wanted to include a different contribution for the different indicators we can give them different weight ( $w_i$ ) in the sum just changing the coefficient value (*note*: the sum of the coefficients must always be equal to one). For example, we can increase the relative importance of land cover indicators (AGR=0,25; FAR=0,25 and NO-NPA=0,20) to obtain PHI (COVER) in column 9 of ejemplo1.xls using the following equation (*note* that we have to decrease the value of the remaining coefficients to keep the sum equal to 1):

$$0.191 \cdot 0.25 + 0.631 \cdot 0.25 + 0.018 \cdot 0.10 + 0.030 \cdot 0.10 + 0.00 \cdot 0.10 + 0.333 \cdot 0.20 = 0,190$$

We can, instead, increase activities indicators (TOTPOP = 0,25; RDENS = 0,20; and IND = 0,25), to obtain PHI (ACTIV) in column 10 of ejemplo1.xls using the following equation:

$$0.191 \cdot 0.10 + 0.631 \cdot 0.10 + 0.018 \cdot 0.25 + 0.030 \cdot 0.20 + 0.00 \cdot 0.25 + 0.333 \cdot 0.10 = 0,222$$

You can try different weighting schemes and formulae for this database in order to see if there are changes in the Potential Human Impact index (PHI) and the subsequent ranking of units. In the Ejemplo1.xls you have to complete the calculations in order to obtain the PHI for all the units of analysis.

### STEP 6. Spatial analysis

A spatial analysis is an essential component of this exercise. This can be done simply by producing maps with the information of each indicator or the **Potential Human Impact Index** for each units of analysis.

We will show how to produce those maps using free distribution software (**Q-GIS**). *Note*: You need to have copied the folder attached "ejemplo1.xls" to your PC. In order to visualize the result of your calculation for PHI index, you have to open the "watershed.dbf" file (it is in ejemplo1 folder) and ejemplo1.xls (from Excel program). Copy the values obtained for PHI from ejemplo.xls, goes to watershed.dbf file, position the cursor on the first row of PHI column and from "edition/special paste" click on "values" and accept. The values you obtained for PHI should appear in this column as simple values (be sure to ask for at least 3 decimals: 0,000 to see the real values). If you want to visualize different PHI you should repeat this procedure as many times as you need. Save the files (watershed.dbf and ejemplo.xls) and leave the program (accept any request about Excel format).

#### 6.1. Download and install the Q-GIS in PC

Download the Q-GIS from <http://www.qgis.org> (in the first paragraph click on (download here). Select the Version 0.90 for Windows platform. You can also download the **User Guide (user\_guide\_in.pdf)**.

**Install the software (execute the downloaded file: qgis\_setup0.9.0.26\_10\_2007.exe)** and open the software (it will open after the installation procedure is finished). A direct

access logo to **Quantum GIS** will appear in your desktop (you can also use it to execute this software).

### 6.2. Open and saving a working Project

From the **Q-GIS** windows click on “**Open a Project**” (4<sup>th</sup> icon from the left, or within “**File**” in the top left). Search for the file “**Salado(BsAs).qgs**” within **ejemplo1** folder provided.

*Note:* if a reading error occurs, just click on “**OK**” and click on the three “**.shp**” files shown in the windows: **Hidrolog.shp**; **study-area.shp** and **watershed.shp** (they are all in the **ejemplo1** folder), then you must “**save the project as**” (3<sup>rd</sup>

icon from the left, or File-“save the project as”) in the folder **ejemplo1** as “**Salado(BsAs).qgs**” (overwrite or replace it).

### 6.3. Visualization of the study area

You can see the study area with the watershed and the units of analysis (sub-watershed) depicted in the Q-GIS (Make sure the different “layers” are open by clicking on each of them until an “X” appears in each small box on the left side of the screen (see **Figure 1**). You can move the layers on the left side to modify the order of visualization (make sure they are in this order: hidrolog, watershed and study-area).

**Figure 1.** Study area: Salado River watershed and subwatershed (Buenos Aires province, R. Argentina).

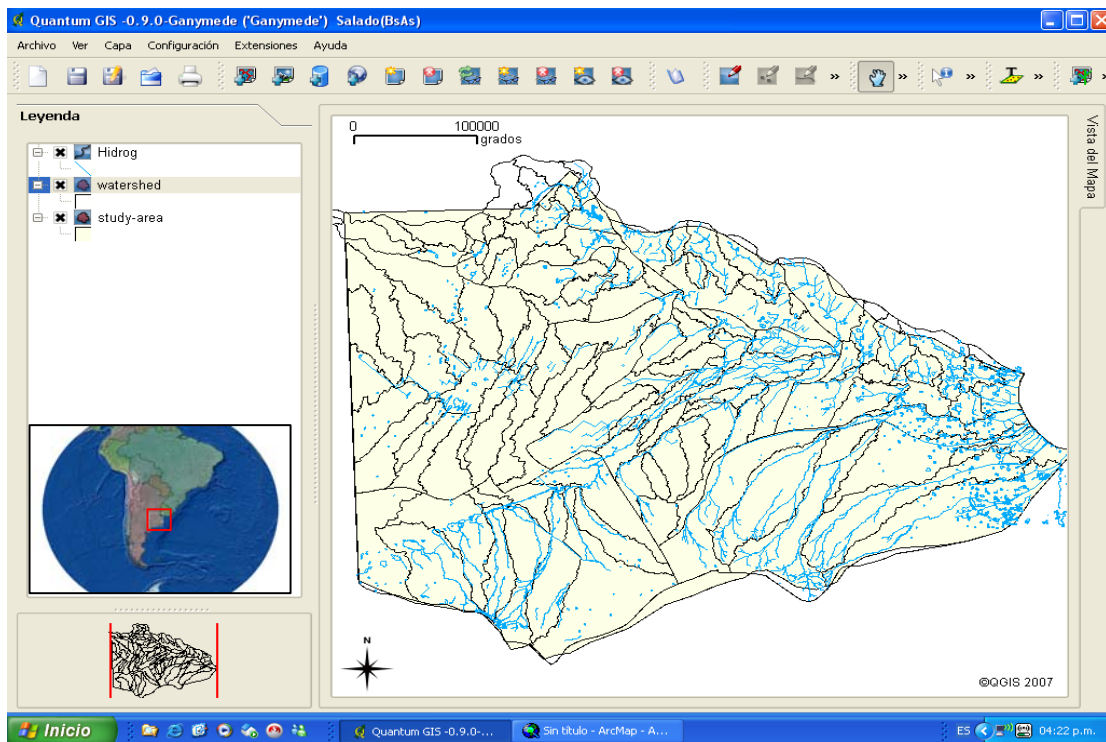

### 6.4. Visualization of PHI Index

You can also visualize the results of your calculation for the **Potential Human Impact Index** obtained above and classify the different units on this basis (see **Figure 2**). Edit the legend for visualization the results doing a double click on “watershed” name. A “**Layer properties**” menu will open. Click in the “**Legend type**” arrow and select “**Graduated**

**symbol**”. Select the classification field to **PHI** and classes number to **5**, and then press “**Classify**”. Select your preferred color for each class and press apply. A **new map** of different units of analysis with different colors will appear in the screen (you can try different options of classification).

**Figure 2.** Spatial analysis of Potential Human Impact in the Salado River watershed and subwatershed (Buenos Aires province, R. Argentina).

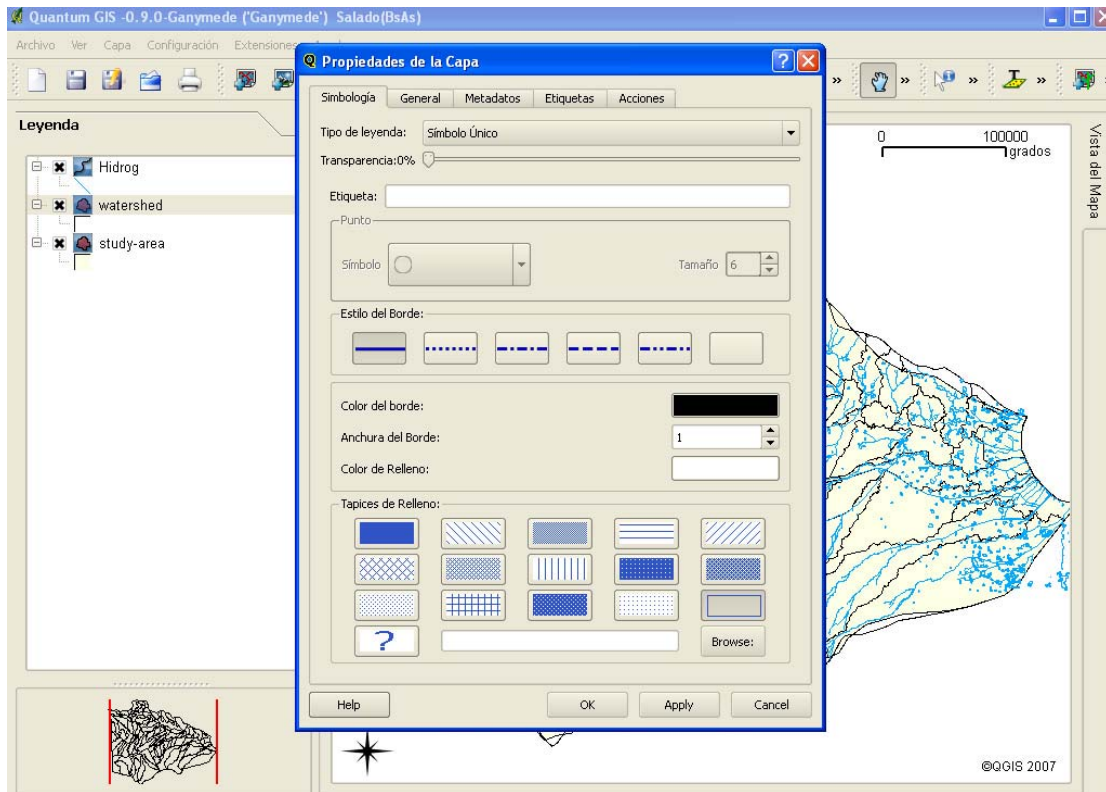

### 3. Analysing the results and discussion

1. What is the most and the less potentially disturbed unit of analysis based on the calculus of PHI index?
2. Do they change depending on different weighting schemes?
3. What are the indicators most important for the estimation of human impact on water quality?
4. Identify one or two variables that can be used as indicators of human impact (not used in this exercise).
5. What are the major impacts related to this land uses and activities (analyze those related to rural development, urban/population distribution and/or industrial profile)?

### REFERENCES

1. Cendrero U. A. 1997. Indicators of sustainable development for decision making. *Naturzale*. 12:5-25.
2. Eastman J. R. 2001. *IDRISI: Guide to GIS and Image processing*. Vol.2. Clark Univrsity.
3. Gabellone N. A., Sarandón R., Claps C. 2003. Caracterización y zonificación ecológica de la cuenca del río Salado. *In: Maiola et al.* (eds). *Inundaciones en el área pampeana*. Editorial de la Universidad de La Plata Cap. 5:36.
4. Gallopin C. G. 1997. Indicators and their use: information for decision-making. *In: B. Moldan, S. Billharz* (eds). *Sustainability Indicators: report of the project on indicators of sustainable development*. SCOPE, John Wiley & Sons, Ltd. 13-27 pp.
5. Hammond A. Adriaanse A., Rodenburg E., Bryant D., Woodward R. 1995. *Environmental Indicators: A Systematic Approach to Measuring and Reporting on Environmental Policy Performance in the Context of Sustainable Development*. World Resource Institute. 43 pp.
6. Hunsaker C.T., Carpenter D.E. (eds.). 1990. *Ecological Indicators for the Environmental Monitoring and Assessment Program*. EPA 600/3-90/060. US Environmental Protection Agency, Office of Research and Development, Research Triangle Park, NC.

7. Mckenzie D. H., Hyatt D.E., McDonald V.J. (ed.). 1992. Ecological Indicators. Vol. 1 & 2. Elsevier Applied Science, London, New York. 1565 pp.
8. Moldan B., Billharz S., Matravars R. (eds). 1997. Sustainability Indicators: A report on the project on indicators of sustainable development. SCOPE 58. John Wiley & Sons. England. 415 pp.
9. Quantum GIS Project. 2004. User and Installation Guide. Version 0.9.0 'Ganymede'. Internet: <http://www.qgis.org>.
10. Treweek J. 1999. Ecological Impact Assessment. Blackwell Science LTD., Oxford. 351 pp.
11. Zalewski M. 2000. Ecohydrology-the scientific background to use ecosystem properties as management tools toward sustainability of water resources. Guest Editorial in Ecological Engineering 16:1-8.

#### ANNEX

1. Folder: **ejemplo1**
2. File: **ejemplo.xls**
3. Program: **Q-GIS**  
([qgis\\_setup0.9.0.26\\_10\\_2007.exe](http://www.qgis.org);  
<http://www.qgis.org>).

## 20. AN EXPERIENCE ON ECOLOGICAL ASSESSMENT OF ESTUARINE OR SEA WATERS.

### Chapter Objectives

To describe a simple ecological monitoring program for coastal or estuarine waters. The contribution of different algal cell size groups, to total phytoplanktonic biomass, will be obtained from periodic measurements of nutrients and photosynthetic pigment concentrations in sea water.



*Guadiana estuary, Portugal (photo NASA, Tomasz Boski)*

**EH principle: 1 – use of biota as impact indicators**

### INTRODUCTION

The alteration of freshwater flows into estuarine and coastal zones affects variables like salinity or residence times of nutrients and can disturb the functioning of coastal ecosystems and the availability of resources (Estevez 2002, see also UNESCO's Ecohydrology Programme at <http://typo38.unesco.org/en/ecohydrology.html>). In this ecohydrological context, the close environment-phytoplankton coupling makes of the coastal phytoplankton communities a good indicator of human disturbances or natural fluctuations in the environmental conditions of estuarine and coastal waters. Nutrient concentrations and phytoplankton biomass estimations are basic variables to assess the ecological regime of marine ecosystems. In addition, phytoplankton size spectrum is closely related to higher food web levels. Thus, these variables can be used to establish an ecological status of sea water masses.

### ELABORATING THE EXPERIMENT

#### 1. General description

Chemical and/or biochemical features of sea water will be compared for, at least, two points/stations expected to be subject to different environmental conditions. Sea water variables to be measured include macronutrient concentrations, chlorophyll *a* concentration and phytoplankton cell size (Sieburth *et al.* 1978, **equation 2** see **Annex**) grouping derived from

marker pigment concentrations. Concentrations of phosphate, silicate, nitrate and ammonium can be determined using appropriated reaction kits or an autoanalyzer and spectrophotometric techniques. After sample filtration, chlorophyll will be extracted and spectrophotometrically measured. Finally, an **HPLC** is necessary for separation and measurement of marker pigments.

#### 2. Experimental design

A first step will be the selection of two sampling stations representing distinct water masses. Those sampling stations should be located at a different distance of the nutrient source (e.g. a river mouth, an aquaculture marine farm), the experiment can be performed during an annual phytoplankton peak, for instance, at springtime. Alternatively, a single coastal station could be sampled at several depths during the season of stronger stratification (e.g. mid-summer). Water samples of 2.5 l should be collected 2-3 times a week during at least 2 weeks, and at a similar time for all sampling days.

Use an oceanographic sampling bottle to collect surface water samples and/or samples from different depths (2 m or more). Keep the samples under cool and dark/shadow conditions until the arrival to the lab. After water sampling the first step before water analyses is the filtration of the samples through a suitable filter (Aminot, Rey 2000). As all the subsequent chemical and biochemical procedures require adequate training, request the assistance of a marine chemistry lab for analysis procedures and lab safety precautions.

**Nutrient concentration.** Determinations of macronutrient concentrations are made in filtered sea water; mainly nitrate, ammonia, phosphate and silicate concentrations. A number of automated or manual methods can be used to analyze macronutrients. It is important to bear in mind that some methods and materials are not suitable for marine water, but only for freshwater analysis. See [Grasshoff \*et al.\* \(1983\)](#) as a reference book for different procedures in sea water analysis.

**Chlorophyll a.** A number of methods exist for **Chl a** measurement. It can be done in vivo by means of an adequately calibrated fluorometer; or it can be determined by retaining phytoplankton in a glass-fiber filter, (GF/C with 0.7  $\mu\text{m}$  nominal pore size) from a known sea water volume, extracting chlorophyll and measuring Chl a concentration spectrophotometrically ([Aminot, Rey 2000](#)). The method of [Aminot and Rey \(2000\)](#) implies absorbance measurements at several wavelengths of both, the chlorophyll extract, and the acidified chlorophyll extract. The extract is acidified by adding two drops of HCl 0.1 N to the spectrophotometer cuvette. Measuring absorbencies after sample acidification is a necessary step to correct for deviations due to the presence of pheopigments a (chlorophyll a degradation products). This method is recommended for estuarine and coastal waters. For **chlorophyll a** concentration measurement see **equation 1** in **Annex**.

**Diagnostic pigments (DP, equation 3 and 4 see Annex).** Filter the pigment extract through a 0.2  $\mu\text{m}$  Teflon filter. The separation of photosynthetic pigments requires **HPLC (High Pressure Liquid Chromatography) techniques (Photo 1)**. At this point, it is necessary to ask for the collaboration of a marine chemistry lab currently analysing photosynthetic pigments, since HPLC procedure requires skilled personnel. [Mueller \*et al.\* \(2003\)](#) provide a detailed guide about phytoplankton HPLC pigment analysis. The HPLC analysis output is a graphical chromatogram in which a number of peaks stand for different pigments; pigment concentrations are estimated from the wide and height of such peaks (**Figure 1** see **Annex**).

A **cell size index (SI)** can be obtained for each sample by using [Bricaud \*et al.\* \(2004\)](#) formula (**equation 5**, see **Annex**).

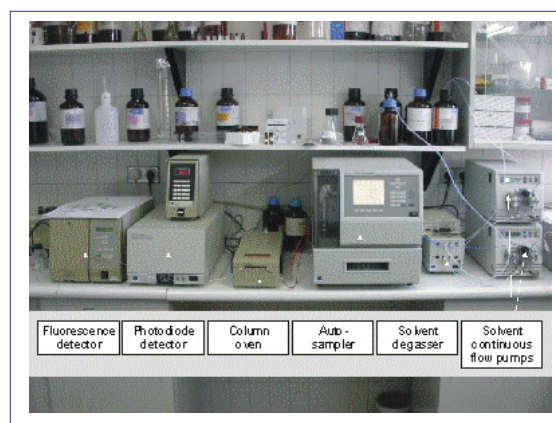

**Photo 1.** *HPLC (High Pressure Liquid Chromatography) equipment to analyse the composition of pigment extracts obtained from water samples.*

### 3. Materials and equipment

#### a) Material and equipment for water sampling and analysis:

- clothing: water proof boots, water proof jacket, use appropriate gloves and protection glasses for all lab works. Manipulate reagents carefully;
- appropriate vessel to get at the sampling stations;
- oceanographic sampling bottle;
- fridge ( $-20^{\circ}\text{C}$  and/or  $-80^{\circ}\text{C}$ , use gloves when handling frozen material);
- pump and vacuum equipment accessories to filter sea water;
- GF/C filters (0.7  $\mu\text{m}$ );
- test tubes and centrifuge tubes;
- materials needed to analyze macronutrients will depend on the availability of equipment and the chosen methodology (automated or manual); see [Grasshoff \*et al.\* 1983](#) for a detailed list of methods and materials;
- As in the case of macronutrient analyses, materials needed to chlorophyll determination will depend on the methodology chosen, e.g., for in vivo measurements a calibrated fluorometer will be necessary; on the other hand, if chlorophyll a is to be extracted, materials like filters, solvents, spectrophotometer etc, will be needed; see [Aminot, Rey \(2000\)](#) for detailed lists of materials;
- HPLC, see [Mueller \*et al.\* \(2003\)](#) for materials needed and ask for the assistance of a marine chemistry lab.

**b) Data analysis:**

- computer;
- spreadsheet software;
- software for graphical representation of data;
- statistical software package.

**c) Safety information**

*Check the weather forecast before going to the field. Use appropriate clothing. Do not walk into deeper water or enter a boat wearing your water proof boots. Beware of touching electric devices with your hands wet. Be very careful when using all electric equipments.*

**4. Organizing the data****Organizing the data**

Organize data in a clear table and in a single worksheet when possible. A suggestion for organizing data is given in **Annex** (see **Table 1**).

**Basic statistical analysis**

The whole data set will comprise about 10 water samples, each one characterized by 12 raw variables (nutrient, chl and pigment concentration) and, at least, 1 derived variable (SI). In this case, a Principal Component Analysis (PCA) would be useful to order the samples as wholes and to quantified differences among them as distances. PCA searches for new variables that maximize the variation among the analyzed items; these new variables are made up of the original ones, and can be used as axes in order to get a graphic representation of the different samples. Usually the first 3 axes comprise a large amount of variation among samples.

Correlation analysis will be suitable to explore the relationships between chemical and biochemical or ecological variables; for example, N/P quotient or Si/N quotient versus Chl a or SI.

**Making graphs**

Three sets of graphs could help to discuss the results, mainly: i) PCA derived graph, ii) graphs associated to correlation analyses, and iii) graphs representing the temporal evolution of different variables.

The first two axes of PCA analysis provide us with a tool for sample grouping and for exploring the variation between and within stations. Graphs associated with correlation analysis could help to decide on the shape of potential relationships. Finally, graphing the temporal evolution of different variables for each station

could be useful in the case of within-station sample variability.

**5. Analyzing the results and discussion**

1. Is there any clear change in nutrient or chl concentration or in SI through time?
2. Can the samples be grouped based on sampling stations or depths?
3. What are the more important variables that make up the first two PCA axes?
4. What is the relationship between nutrients and [Chl]?
5. What is the relationship between nutrient ratios and phytoplanktonic communities?
6. Is there any clear relationship between size of phytoplanktonic cells and nutrient ratio or concentration?

**REFERENCES**

1. Aminot A., Rey F. 2000. Standard procedure for the determination of chlorophyll a by spectroscopic methods. ICES TIMES. 17 pp.
2. Bricaud A., Claustre H., Ras J., Oubelkheir K. 2004. Natural variability of phytoplanktonic absorption in oceanic waters: Influence of the size structure of algal populations. Journal of Geophysics Research 109:. C11010, doi: 10.1029/2004JC002419.
3. Estevez. E.D. 2002. Review and assessment of biotic variables and analytical methods used in estuarine inflow studies. Estuaries 25: 1291-1303.
4. Grasshoff K., Ehrhardt M., Kremling K. (eds). 1983. Methods of Seawater Analysis 2nd edition. Verlag Chemie, Weinheim. Germany..
5. Mueller J.L., Bidigare R.R., Trees C., Dore J., Karl D., van Heukelem L. 2003. Ocean optics protocols for satellite ocean color sensor validation, Revision 4, Volume V: Biogeochemical and bio-optical measurements and data analysis protocols. NASA/TM-2003-211621 / Rev4-Vol.V.
6. Sieburth J., Smetacek V., Lenz J. 1978. Pelagic ecosystem structure: Heterotrophic compartments of the plankton and their relationship to plankton size fractions. Limnology and Oceanography 23:1256-1263.
7. Vidussi F., Claustre H., Manca B.B., Luchetta A., Marty J-C. 2001. Phytoplakton pigment distribution in relation to upper thermocline circulation in the eastern Mediterranean sea water during winter. Journal of Geophysics Research 106:19939-19956.



**Figure 1.** Graphical output or chromatogram provided by HPLC analysis: peaks are identified and concentrations provided.

### SAMPLE INFORMATION

Sample Name:	27516 RPAP(B) 27.04.07 1L	Acquired By:	System
Sample Type:	Unknown	Date Acquired:	5/22/07 9:08:04 AM
Vial:	2	Acq. Method Set:	Fluorescencias mas Diadino
Injection #:	1	Date Processed:	5/22/07 9:38:21 AM
Injection Volume:	100.00 ul	Processing Method:	450b
Run Time:	30.0 Minutes	Channel Name:	Extract 450.0
Sample Set Name:	220507	Proc. Chnl. Descr.:	PDA 450.0 nm

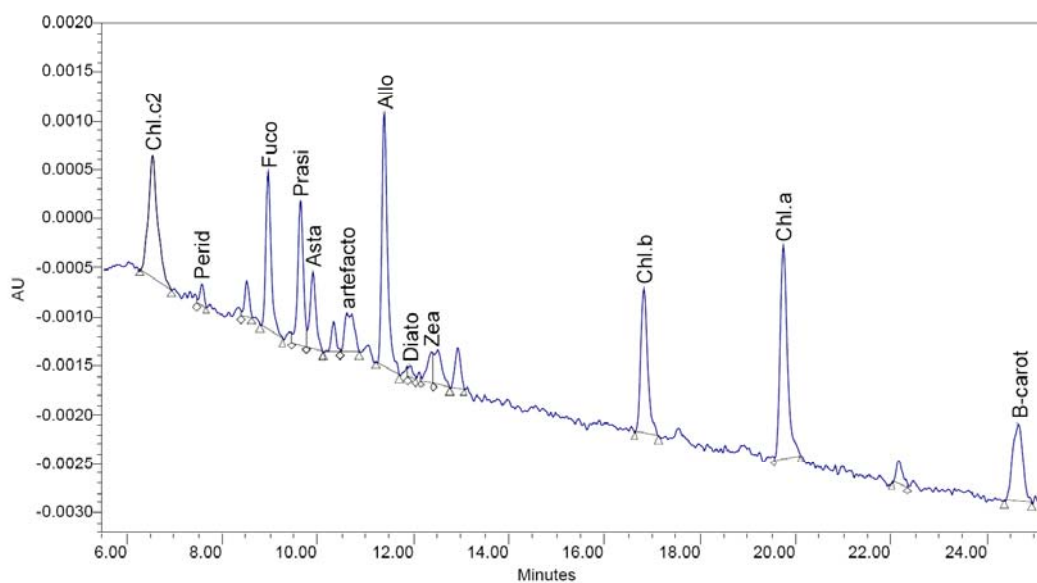

	Peak Name	RT	Area	% Area	Height	Amount	Units	PDA Match1 Spect. Name
1	Chl.c2	6.524	16797	11.54	1247	0.014	mg/l	Chl.C2 (Std.13)
2	Perid	7.558	1360	0.93	218	0.003	mg/l	
3	Fuco	8.943	12626	8.67	1605	0.017	mg/l	Fucoxanthin
4	Prasi	9.622	11897	8.17	1476	0.016	mg/l	
5	Asta	9.880	6730	4.62	778	0.012	mg/l	Violax
6	artefacto	10.599	5601	3.85	393		mg/l	
7	Allo	11.374	21511	14.77	2583	0.016	mg/l	Alloxanthin
8	Diato	11.920	708	0.49	132	0.002	mg/l	
9	Zea	12.368	3301	2.27	326	0.004	mg/l	
10	Chl.b	16.807	15152	10.41	1477	0.056	mg/l	Chl b
11	Chl.a	19.727	23376	16.05	2176	0.169	mg/l	Chl a
12	B-carot	24.648	12290	8.44	807	0.013	mg/l	B-carot
	None							



## 21. CYTOGENETICS OF BIVALVES AS POSSIBLE INDICATOR OF ENVIRONMENTAL ADVERSITY.

### Chapter objectives

To demonstrate that atypical cytogenetic features in bivalve species could be considered alerting indicators of poor environment health.

**EH principle: 1 – quantification of threats**



*Ruditapes decussatus* (photo IPIMAR)

### INTRODUCTION

A large percentage of anthropogenic pollutants released into the marine environment consist of potentially genotoxic, carcinogenic and mutagenic substances. Exposure to these chemicals/pollutants, may result, namely, in karyotype disturbances such as aneuploidy (the occurrence of one or more extra or missing chromosomes or any chromosome number that is not an exact multiple of the haploid number). The use of aquatic organisms, such as bivalves as sentinel species, for in situ environmental assessment is becoming a widely accepted method for identifying risks to ecosystems and human health (e.g. Leitão et al., 2008). At the DNA and chromosome levels, marine invertebrates express indeed similar types of induced damage to that found in higher organisms (Dixon et al., 2002). A renewed interest in the chromosomal or cytogenetic status of various species of the bivalves has been generated by their importance as ecological damage case studies (e.g. Barsiene and Lovejoy, 2000). Indeed karyotype disturbances such as aneuploidy have been observed in bivalves exposed to chemicals, either natural or produced by human activity (e.g. Bouilly et al. 2003, 2004; Barsiene 1994). Dixon et al. (1982) showed that the level of aneuploidy was higher in *Mytilus edulis* embryos descended from parents originating from a polluted dock (King's Dock, Swansea, South Wales, UK) containing organic contaminants (hydrocarbons and polycyclic compounds) and heavy metals. Cytogenetic analysis also showed the presence of disseminated neoplasia in gill tissue of the Baltic clam *Macoma balthica*, with high accumulated tissue concentrations of trace metals (As, Ag, Cd, Pb, Cu and Zn) from the Gulf of Gdansk, Poland (Sokolowski et al., 2004). Polyploidy was also observed recently in the

freshwater bivalve *Anodonta cygnea* exposed to a polluted environment (Carrilho et al., 2008). In a recent study a chromosomal fission in bivalves was observed for the first time, in the cockle *Cerastoderma edule* in populations from the Galician coast, which had suffered hydrocarbonate pollution after the Prestige oil spill (Leitão et al., 2008).

### ELABORATING THE EXPERIMENT

#### 1. General description

The objective of this work is to determine with a few selected bivalve species the possible role of chromosomal abnormalities in bivalves as alerting indicators of poor environment health. For that, specimens of a few local bivalve species (such as *C. edule*, *Scrobicularia plana*, *Crassostrea* sp, *Mya arenaria* or *M. balthica* among others) should be collected from at least two distinct sampling sites: A) a pristine one, and (B) one for which there is already data that puts on evidence the presence of anthropogenic/other pollution. In order to select both sampling sites, first of all a thorough bibliographic review should be made on local environmental data already available.

#### 2 - Materials and equipment:

- a) Sampling equipment
  - recipients and tools for bivalve collection and transport to the lab;
  - clothing: water proof boots, water proof jacket.
- b) Laboratory experiments
  - aquarium;
  - peristaltic pump;
  - dissection material

- pipettes;
- heating plaque;
- microscope and coupled camera;
- microscope slides;
- staining recipients;
- reagents: colchicine, sodium citrate, acetic acid and absolute ethanol and giemsa.

### c) Data analysis

- computer;
- image editing software.

## 3 - Experiment description

### Chromosome preparation:

Whole juvenile animals from both locations A and B (and from the different selected model bivalve species) should be incubated (overnight) for 8-9h in a 0.005 % solution of colchicine in seawater (Photo 1).



**Photo 1-** Incubation in colchicine overnight.

Then the gills should be dissected out and treated for 30 min in 0.9 % sodium citrate in distilled water. Afterwards the material must be fixed in a freshly prepared mixture of absolute alcohol and acetic acid (3:1) with three changes of 20 min each. Fixed pieces of gill from each individual should then be dissociated in 50 % acetic acid with distilled water solution. Slides preparation should follow the air-drying technique of Thiriou-Quévieux and Ayraud (1982) (Photo 2), in which the solution obtained by the previous dissociation should be dropped at approximately 50cm high into a hot plaque at

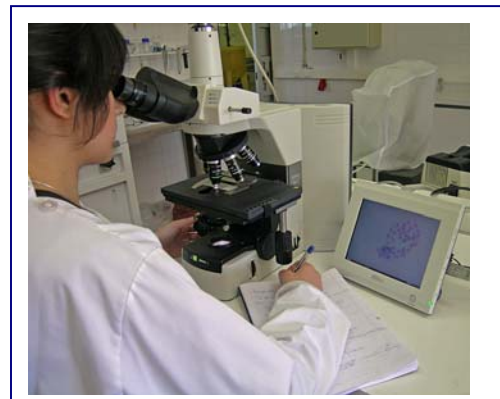

**Photo 2-** Air drying technique for chromosomal slide preparations using an heating plaque.

The material (interphase nucleous and metaphases) will attach to the slide and afterwards the exceed liquid should be aspired gently.

### Microscopy and Image processing

The microscopic preparations performed in the previous point should be stained with Giemsa at 4%, pH 6.9 for 10 to 15 minutes. When observing the obtained slides on microscope we will be able to see both interphase nucleous and metaphases. Images of metaphases of the selected species from both locations A and B should be acquired with a camera coupled to the microscope (Photo 3).



**Photo 3-** Microscopic observation of the slides with coupled camera.

#### 4 - Organizing the data

Digitized photos should be uploaded to an image editing software. First of all chromosomes should be counted in order to determine the diploid number ( $2n$ ) of each metaphases. Karyotypes of the individuals from both sampling sites should be organised from the metaphases by “cutting and placing the chromosomes according to their size and morphological characteristics (Figure 1) and following the already published diploid number and karyotype formulae of the selected bivalve model species.

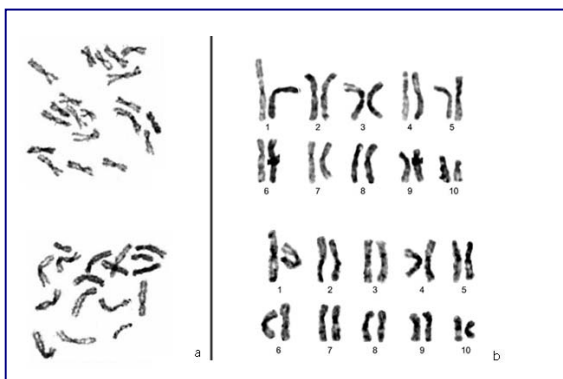

**Figure 1-** Example of metaphases (a) and karyotypes (b) of two oyster species (Leitão et al., 2004).

#### 5. Analysing the results

Analyse the diploid numbers and the karyotypes of each individual from the different species and for both sampling sites A and B, in order to try to answer the following questions:

-Is the diploid number found the normal diploid number for the species? Or are there missing (or extra) chromosomes?

-Try to identify which chromosomal pair is missing (or has an extra) chromosome in the karyotypes with  $2n$  different from the normal one.

-Attempt to identify possible structural chromosomal alterations by identifying alterations in the normal (already published) morphology of the chromosomes.



-Seek to establish a relationship between the presence (and amplitude) of the chromosomal aberrations (both numerical and structural) and the sampling site: A (pristine) and B (polluted).

#### 6- Discussion

Discuss the results obtained in this study with others on the same subject already published.

#### REFERENCES

1. Barsiene, J., Lovejoy, D.B. 2000. Environmental Genotoxicity in Klaipeda Port Area. *Internat. Rev. Hydrobiol.* 85, 663-672.
2. Baršienė, J., 1994. Chromosome set changes in molluscs from highly polluted habitats. In: *Genetics and evolution of aquatic organisms* (AR Beaumont, ed) Chapman and Hall, London, 344-447.
3. Bouilly, K., Leitão, A., McCombie, H., Lapègue, S., 2003. Impact of atrazine on aneuploidy in Pacific oysters, *Crassostrea gigas*. *Environmental Toxicology and Chemistry* 22, 219-223.
4. Bouilly, K., McCombie, H., Leitão, A., Lapègue, S. 2004. Persistence of atrazine impact on aneuploidy in Pacific oysters, *Crassostrea gigas*. *Marine Biology* 145, 699-705.
5. Carrilho J., Leitão A., Vicente C. and Malheiro I. 2008. Cytogenetics of *Anodonta cygnea* (Mollusca:Bivalvia) as possible indicator of environmental adversity. *Estuarine Coastal and Shelf Science*, 80: 303–306
6. Dixon, D.R., 1982. Aneuploidy in mussel embryos *Mytilus edulis* L..originating from a polluted dock. *Mar. Biol. Lett.* 3, 155–161.
7. Leitão A., Chaves R., Santos S., Guedes-Pinto H. and Boudry P. 2004. Restriction Enzyme Digestion Chromosome banding in *Crassostrea gigas*, *Crassostrea angulata*, *Ostrea edulis* and *Ostrea conchaphila*. *Comparative karyological analysis within Ostreidae*. *Genome* 47: 781-788.
8. Leitão A., Chaves R., Joaquim S., Matias D., Ruano F. and Guedes-Pinto H. 2008. Supernumerary chromosomes on Southern European populations of the cockle *Cerastoderma edule*: Consequence of environmental pollution? *Estuarine Coastal and Shelf Science*, 79: 152-156.
9. Sokolowski, A., Wolowicz, M., Hummel, H., Smolarz-Gorska, K., Fichet, D., Radenac, G., Thiriot-Quievreux, C., Namiesnik, J., 2004. Abnormal features

- 
- 
- of *Macoma balthica* (Bivalvia) in the Baltic Sea: alerting symptoms of environmental adversity? *Marine Pollution Bulletin* 49 (1-2), 17-22.
10. Thiriot-Quiévreux, C., Ayraud, N., 1982. Les caryotypes de quelques espèces de bivalves et gastéropodes marins. *Marine Biology* 70, 165-175.

## APPENDIX

### Glossary of terms

**ALGAE**- microscopic, usually unicellular, plants.

**ALLOCHTHONOUS** organic matter – organic matter transported into a aquatic ecosystems from adjacent ecosystems.

**ANAEROBES** – organisms living in anaerobic conditions and gaining energy from chemical reactions which are not based on oxygen transformations.

**AUTOCHTHONOUS** – produced within a water body.

**BIOASSESSMENT (BIOASSAY)** - Uses biota as the endpoint to represent environmental conditions and assess environmental quality.

**BIODEGRADATION** – the gradual destruction of a material due to natural or artificially induced biological activity.

**BIOMANIPULATION** – all methods of changing biological structure of an ecosystem in order to improve water quality.

**BIOMASS** – the quantity of living organisms expressed in units of volume or mass, generally related to a unit of volume or area within a water body. Also organic material, usually plant or animal waste, especially used as fuel.

**BIOTOPE** – populations of all species living in a particular space.

**BLOOMS** – high concentrations of phytoplankton biomass.

**BUFFER** – a zone of given radius around a geographical object (point, line, area).

**CARRYING CAPACITY** – the dynamic equilibrium around which a population fluctuates; regulated by available space and the amount (and quality) of available resources.

**CASCADING EFFECT** - transmission of changes within a given trophic level to lower ones.

**CHELATING** – capable of forming a ring-shaped molecular structure and locking a metal ion in place, thereby reducing their activity.

**CYANOBACTERIA** [also Cyanophytes or blue-green algae] – a group of phytoplankton, some of which can produce toxins, regulate their depth using a gas-vacuole buoyancy mechanism, and/or fix atmospheric nitrogen for use in growth. They often occur in eutrophic waters as a bloom.

**CYANOTOXINS** - toxins produced by cyanobacteria and classified as: hepatotoxins, neurotoxins, dermatotoxins and lipopolisaccharides (LPS).

**DATA MODEL** – a formal method of arranging data to represent an observed environment.

**DATABASE** – a computer file containing data, organized, inter alia, as a set of tables or coordinates of the points and their attendant attributes.

**DENITRIFICATION** – the microbiologically-mediated reduction of oxygenated nitrogen compounds to gaseous nitrogen.

**DENITRIFYING BACTERIA** – the group of bacteria which utilize nitrate in one of three metabolic pathways:

- a) without accumulating nitrite,
- b) with transient accumulation of nitrite, and
- c) in a two-step denitrification process that transforms nitrate into gaseous nitrogen.

**DIATOMS** [also Bacillariophytes] - a group of algae with siliceous walls.

**DIGITAL TERRAIN MODEL (DTM)** – data which depict the relief of a given area of terrain using a grid or irregular triangular network and contour elevations.

**DIGITIZE** – a means of entering geographical data into computerized databases from analogue maps.

**DINOFLAGELLATES** – a group of phytoplankton with flagella, or whip-like appendages, by which the organisms have limited movement.

**DIVERSITY** – the proportion of a given of species within a sample population. Diversity may be calculated using the Shannon Index (H), where:  $H' = - \sum O_i \ln p_i$  .  $p_i$  is the ratio of each component (the % of a given species) to the total value (all species=100%). The index may be scaled from 0 to 1, where 0 is the lowest possible diversity and 1 is the maximum possible diversity by dividing H' by  $\ln S$ , where S is the number of species having the indicated  $p_i$  value (after Odum 1980).

**ECOLOGICAL INTEGRITY** – the condition of the biotic (biological community) and abiotic (non-biological; water chemistry and habitat) components of unimpaired water bodies, as measured by assemblage structure and function, water chemistry, and habitat measures.

**ECOREGIONS** – a relatively homogeneous area defined by the similarity of climate, landform, soil, potential natural vegetation, hydrology, or other ecologically relevant variables.

**ECOTONE** – the transition zone between two different types of ecosystems, such as a river and a meadow, characterized by very high biodiversity; ecotones may play an important role as buffers, modifying and limiting flows of nutrients and pollutants between ecosystem components.

**EFFICIENT INFILTRATION** - the amount of precipitation water, which passes (percolates) from the unsaturated zone into the ground water. Efficient infiltration is sometimes called recharging infiltration.

**EH** – ecohydrology

**ELISA** (enzyme-linked immunosorbent assay) – sensitive biochemical method for detecting compounds that interact with specific antibodies; useful for rapid sample screening for microcystins.

**EUTROPHICATION**- an increase in the concentration of chemical nutrients in an ecosystem to an extent that increases in the primary productivity of the ecosystem. Depending on the degree of eutrophication, subsequent negative environmental effects such as anoxia and severe reductions in water quality, fish, and other animal populations may occur

**FLUORESCENCE** – the process whereby light is absorbed at one wavelength and almost instantaneously emitted at new and longer wavelengths by an organic molecule

**GEOREFERENCE** – the relationship between raster data and cartographic coordinates.

**GREEN ALGAE** [also Chlorophytes] – a group of algae which are usually a good food for zooplankton.

**HPLC** (high performance liquid chromatography) - analytical method for separation and quantification of compounds in liquid solvents.

**IN SITU** – in the original location.

**IN VIVO** – in living organisms.

**INFILTRATION** – the slow passage of water (percolation), which comes from precipitation, rivers, water reservoirs and condensation of water vapour on soil, through the unsaturated zone to the saturated zone. INFILTRATION UNITS could be: l km-2 or mm year-1.

**INTERPOLATION** – making predictions based on measurements done only in a certain area.

**IWM** – Integrated Watershed Management.

**KRIGING** – an interpolation technique based on a theory of the semivariogram.

**MODEL** – a simplification and abstraction of reality. Models can be seen as a data set representing the structure of geographical objects, as well as a set of logical expressions and mathematical equations used to simulate processes. Models may also be physical representations of geographic features.

**MULTIMETRIC APPROACHES** – an analysis technique using several measurable characteristics of a biological assemblage.

**MULTIVARIATE COMMUNITY ANALYSIS** – statistical methods (e.g., ordination or discriminant analysis) for analyzing physical and biological community data using multiple variables (quantitative or nominal).

**NON-POINT SOURCE POLLUTION** – pollution entering water bodies from diffused sources, including surface and subsurface runoff, nutrient leaching, and erosion, mainly from degraded landscapes (e.g., landscapes degraded due to agriculture, deforestation, etc.).

**NUTRIENT CONCENTRATION** – the amount of a nutrient in a given volume of water.

**NUTRIENT LOAD** – the amount of a nutrient transported into a water body by rivers, sewage discharges, etc., over a given period of time, calculated as concentration multiplied by discharge.

**NUTRIENTS** - chemical elements necessary for growth and development of vegetation. The main nutrients are phosphorus, nitrogen, and carbon. Increased nutrient concentrations stimulate the process of eutrophication in aquatic ecosystems.

**PHOSPHATASE** – a group of hydrolytic enzymes liberating the orthophosphate ion from organic compounds.

**PHYCOCYANIN** – a photosynthetic pigment characteristic of cyanobacteria.

**PHYTOEXTRACTION** – removal of chemical substances by plants.

**PHYTOPLANKTON** – the algal component of plankton, which are free-living organisms within an aquatic environment.

**PHYTOREMEDIATION** – removal of contamination through the natural process of plant uptake.

**PIEZOMETER** – a pipe-like trap for ground waters with perforated ends, placed in water bearing layers to measure ground water elevations; when placed in fields, ground water flows can be measured using tracers.

**PLANKTON**- consists of any drifting organisms (animals, plants, archaea, or bacteria) that inhabit the pelagic zone of oceans, seas, or bodies of fresh water. Plankton are defined by their ecological niche rather than their phylogenetic or taxonomic classification. They provide a crucial source of food to more familiar aquatic organisms such as fish. Though many planktonic species are microscopic in size, the plankton includes organisms covering a wide range of sizes, including large organisms such as jellyfish

**POINT SOURCE POLLUTION** – pollution entering water bodies from concentrated outflows (e.g., pipes transporting municipal and industrial sewage, water from purification plants, irrigation channels, etc.).

**PPIA** (protein phosphatase inhibition assay) – sensitive biochemical method that uses biochemical activity to measure the presence of microcystin and nodularin toxins.

**REFERENCE CONDITION** – the chemical, physical, or biological quality, exhibited at either a single site or an aggregation of sites, representing a seminatural or reasonably attainable condition at the least impaired reference sites.

**RETENTION TIME** [also Residence time, – the ratio of volume and flow of a water body

**SHOAL** – a large number of fish swimming together.

**STABILIZATION** – a process designed to limit the mobility of toxic chemicals.

**SUCCESSION** – is a widely-accepted, biological concept implying a sequence in which species or group of species dominate a plant community. **SUCCESSION** – the biological concept implying a sequence in which species or groups of species, dominate a community.

**SURFACE RUNOFF** – surface flow caused by rainfall, transporting solids, nutrients, and pollutants downhill into aquatic systems.

**WATER BALANCE** - balance sheet of all water fluxes entering and leaving an ecosystem or landscape.

**WATER DEFICIT** – difference between evapotranspiration and water supplies (precipitation and water retention) within agricultural landscapes.

**WETLAND** – a natural or constructed system, permanently or periodically flooded, that can act as water purification systems or nutrient sinks. Purification is enhanced by the activity of vegetation and variety of microbiological and biogeochemical processes taking place within the substrate of the wetland. Wetlands are defined by the presence of hydric soils, characteristic types of vegetation, and a high water table.

**Internet resources**

<http://typo38.unesco.org/en/ecohydrology.html>

<http://unesdoc.unesco.org/images/0015/001529/152987e.pdf>

[http://www.unep.or.jp/etc/Publications/Water\\_Sanitation/integrated\\_watershed\\_mgmt\\_manual/](http://www.unep.or.jp/etc/Publications/Water_Sanitation/integrated_watershed_mgmt_manual/)

<http://www.unep.or.jp/etc/Publications/Freshwater/FMS5/index.asp>

[http://www.elsevier.com/wps/find/bookdescription.cws\\_home/712546/description#description](http://www.elsevier.com/wps/find/bookdescription.cws_home/712546/description#description)

[http://www.sciencedirect.com/science?\\_ob=PublicationURL&\\_tockey=%23TOC%236776%232006%23999299998%23634379%23FLA%23&\\_cdi=6776&\\_pubType=J&\\_auth=y&\\_acct=C000050221&\\_version=1&\\_urlVersion=0&\\_userid=10&md5=fcd466d2b3ccc6217276db2cebc26358](http://www.sciencedirect.com/science?_ob=PublicationURL&_tockey=%23TOC%236776%232006%23999299998%23634379%23FLA%23&_cdi=6776&_pubType=J&_auth=y&_acct=C000050221&_version=1&_urlVersion=0&_userid=10&md5=fcd466d2b3ccc6217276db2cebc26358)



